

TECHNICAL MANUAL

OPERATOR'S AND ORGANIZATIONAL
MAINTENANCE MANUAL
(INCLUDING REPAIR PARTS AND
SPECIAL TOOLS LISTS)

SPACE HEATER ARCTIC
(NSN 4520-01-444-2375)

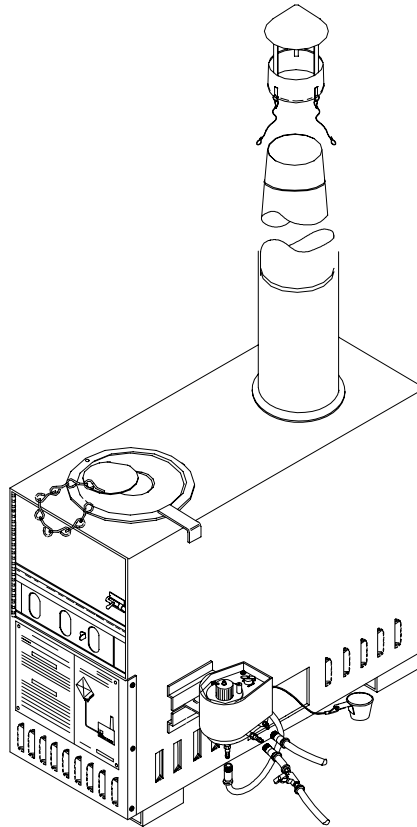

DISTRIBUTION STATEMENT A – Approved for public release; distribution is unlimited.

HEADQUARTERS, DEPARTMENT OF THE ARMY

01 DECEMBER 2001

THIS PAGE INTENTIONALLY LEFT BLANK



WARNING!
Fire or Explosion

Interchanging fuel flow control valves between Space Heater Arctic (SHA) and H-45 Large Radiant Space Heater is not allowed! Operating a heater with an incorrect valve could result in fire or explosion!

Do not use unauthorized fuels! Use of unauthorized fuel may result in fire/explosion!

Tent exhaust opening closure flap must be rolled and tied securely. Tent may catch fire if hot stack assembly contacts the flap.

Poorly fitted stack sections may allow hot stack to fall on tent and start a fire, or deadly carbon monoxide to leak into tent. Ensure sections seat together fully.

Heat or sparks from stack assembly could ignite fuel supply. Set up fuel supply on a clear site seven feet (approx. 2.5 meters) from tent and away from flame sources.

If fuel flow control valve assembly is improperly positioned or if bracket is bent, a fuel overflow could occur inside burner shell and cause a fire or explosion.

For safe operation, be sure to allow at least one (2) feet (61 cm) of space between the heater and the tent wall. Never relight a extinguished flame while the heater is hot. Be sure to allow the heater to cool completely before attempting to relight. Do not attempt to replenish the fuel supply while the heater is in operation. Be certain that there is no open flame in the vicinity of liquid fuel.



WARNING!
Stack Fire Potential

When operating the heater in solid fuel mode, a buildup of creosote can accumulate on the inside surface of the stack assembly that may result in a fire inside the stack. To prevent creosote buildup when operating with solid fuel, the stack assembly should be cleaned daily. Failure to do so may result in a fire causing severe injury or death.



WARNING!

Explosion Potential - Do Not Use Unauthorized Fuels

Gasoline, JP-4, Used Motor Oil, Solvents or other unauthorized fuels should **NOT** be used with the SHA under any circumstance. **Only approved liquid and solid fuels may be used.** Using unauthorized fuels in the SHA will create a fire danger and potential for explosion.



WARNING!
Carbon Monoxide

During operation, the SHA produces harmful carbon monoxide (CO) and other gases. Carbon monoxide is a colorless, odorless, and tasteless gas. Mild cases of carbon monoxide poisoning can cause symptoms such as nausea, dizziness or headaches. Severe cases of carbon monoxide poisoning can result in brain damage, heart damage or death. Remember that although CO has no telltale odor, it may mix with other odors which mask its presence; therefore, CO can be present within a mix of seemingly harmless odors.

To prevent CO poisoning, ensure that the SHA exhaust stack sections fit together snugly and that the exhaust gases are properly vented through the roof of the shelter.

The best way to prevent CO poisoning is to keep the SHA in good working order. Ensure that all possible sources of CO leakage have been repaired and that the operating space is well ventilated.



WARNING!
Hot Surfaces

Do not attempt to handle or perform services on an SHA that has recently been in operation. Let the space heater cool down before performing these procedures to avoid the possibility of serious burns.



WARNING!
Two Person Lift

The SHA weighs approximately 40 pounds (18 kg). Two persons must carry the SHA when lifting or lowering the unit from 3 feet or more. Be sure to lift with legs, not back, to prevent injury.



WARNING!
Cut Hazard

Some metal components of SHA may have sharp edges. Be careful when handling and assembling the SHA to prevent cuts.

TM 10-4520-261-12&P



WARNING!
Freeze Hazard

Severe injury may occur to personnel handling metal parts without protective gloves when temperatures are below freezing. Skin may freeze upon contact and tear from the flesh.

Do not allow fuel to come in contact with bare skin. Even though fuel does not freeze, it is extremely cold and will burn exposed skin on contact. Wear protective gloves whenever handling or working with liquid fuel.

THIS PAGE INTENTIONALLY LEFT BLANK

TM 10-4520-261-12&P

INSERT LATEST UPDATED PAGES / WORK PACKAGES DESTROY SUPERSEDED DATA

LIST OF EFFECTIVE PAGES

Note: The portion of text affected by the update is indicated by a vertical line in the outer margins of the page. Updates to illustrations are indicated by miniature pointing hands. Updates to wiring diagrams are indicated by shaded areas.

Dates of issue for original and updated pages / work packages are:

Original.....01 December 2001

Revision

TOTAL NUMBER OF PAGES FOR FRONT AND REAR MATTER IS 23 AND TOTAL NUMBER OF WORK PACKAGES IS 045 CONSISTING OF THE FOLLOWING:

Page / WP No.	*Revision No.	Page / WP No.	*Revision No.
Front Cover	0		
a-b	0		
A-B	0		
i-iii(iv Blank)	0		
WP 0001 thru 0045	0		
Index	0		
Authentication Page	0		
Sample DA Form 2028	0		
Blank DA Form 2028	0		
Back Cover	0		

*Zero in this column indicates an original page or work package

THIS PAGE INTENTIONALLY LEFT BLANK

TECHNICAL MANUAL

**OPERATOR'S AND ORGANIZATIONAL MAINTENANCE MANUAL
(INCLUDING REPAIR PARTS AND SPECIAL TOOLS LISTS)**

SPACE HEATER ARCTIC (SHA)

(NSN 4520-01-444-2375)

You can help improve this manual. If you find any mistakes or if you know of a way to improve the procedures, please let us know. Mail your letter together with DA Form 2028 (Recommended Changes to Publications and Blank Forms), located in the back of this manual, directly to: Commander, U.S. Army Soldier and Biological Chemical Command, ATTN: AMSSB-RIM-E(N), Kansas Street, Natick, MA 01760-5052. You may also send in your recommended changes via electronic mail directly to amssb-rim-e@natick-amed02.army.mil. A reply will be furnished to you. Instructions for sending an electronic 2028 may be found at the back of this manual immediately preceding the hard copy 2028.

DISTRIBUTION STATEMENT A – Approved for public release. Distribution is unlimited.

TABLE OF CONTENTS

	WP Sequence No.
WARNING SUMMARY	
HOW TO USE THIS MANUAL	
CHAPTER 1 - INTRODUCTORY INFORMATION WITH THEORY OF OPERATION	
SCOPE	0001 00
MAINTENANCE FORMS RECORDS AND REPORTS	0001 00
REPORTING EQUIPMENT IMPROVEMENT RECOMMENDATIONS (EIRS)	0001 00
CORROSION PREVENTION AND CONTROL (CPC)	0001 00
DESTRUCTION OF ARMY MATERIEL TO PREVENT ENEMY USE.....	0001 00
NOMENCLATURE CROSS-REFERENCE LIST	0001 00
LIST OF ABBREVIATIONS/ACRONYMS	0001 00
SAFETY, CARE AND HANDLING, WARNINGS, CAUTIONS AND NOTES	0001 00

HEADQUARTERS, DEPARTMENT OF THE ARMY

01 DECEMBER 2001

TABLE OF CONTENTS - Continued

	WP Sequence No.
EQUIPMENT CHARACTERISTICS, CAPABILITIES AND FEATURES	0001 00
LOCATION AND DESCRIPTION OF MAJOR COMPONENTS	0002 00
DESCRIPTION OF SYSTEM COMPONENTS	0002 00
EQUIPMENT DATA	0002 00
COMMON TOOLS AND EQUIPMENT	0002 00
THEORY OF OPERATION	0003 00

CHAPTER 2 - OPERATOR INSTRUCTIONS

GENERAL	0004 00
CONTROLS AND INDICATORS	0004 00
SITING REQUIREMENTS	0005 00
ASSEMBLY AND PREPARATION FOR USE	0005 00
DECALS AND INSTRUCTION PLATES	0005 00
SHA OPERATING PROCEDURES	0005 00
PREPARATION FOR MOVEMENT	0005 00
PREPARING SHA AND ASSOCIATED EQUIPMENT FOR STORAGE	0005 00
OPERATION IN UNUSUAL ENVIRONMENT/WEATHER CONDITIONS	0006 00

CHAPTER 3 – OPERATOR TROUBLESHOOTING AND SERVICE PROCEDURES

GENERAL INFORMATION	0007 00
MALFUNCTION SYMPTOM INDEX	0008 00
TROUBLESHOOTING PROCEDURES	0009 00
PREVENTIVE MAINTENANCE CHECKS AND SERVICES (PMCS)	0010 00
OPERATOR MAINTENANCE	0011 00

CHAPTER 4 – UNIT MAINTENANCE INSTRUCTIONS

SERVICE UPON RECEIPT	0012 00
UNIT TROUBLESHOOTING PROCEDURES	0013 00
CLEANING	0014 00
DENT REMOVAL	0015 00
STACK CAP ASSY WIRE ROPES AND TENT LINES	0016 00
FUEL HOSES	0017 00
FUEL FLOW CONTROL VALVE	0018 00
FUEL FLOW CONTROL VALVE CUP & CABLE ASSY	0019 00
FUEL FLOW CONTROL VALVE BRACKET	0020 00
BURNER SHELL AND D-TUBE ASSEMBLIES	0021 00
PREP FOR SHIPMENT OR STORAGE	0022 00

CHAPTER 5 - SUPPORTING INFORMATION

REFERENCES	0023 00
MAINTENANCE ALLOCATION CHART FOR SHA	0024 00

TABLE OF CONTENTS - Continued

	WP Sequence No.
INTRODUCTION TO REPAIR PARTS AND SPECIAL TOOLS LIST	0025 00
REPAIR PARTS AND SPECIAL TOOLS LIST – GROUP 01 STACK CAP ASSY	0026 00
REPAIR PARTS AND SPECIAL TOOLS LIST – GROUP 02 STACK ASSY	0027 00
REPAIR PARTS AND SPECIAL TOOLS LIST – GROUP 03 HEATER BODY ASSY.....	0028 00
REPAIR PARTS AND SPECIAL TOOLS LIST – GROUP 04 LID ASSY.....	0029 00
REPAIR PARTS AND SPECIAL TOOLS LIST – GROUP 05 FUEL FLOW CONTROL ASSY	0030 00
REPAIR PARTS AND SPECIAL TOOLS LIST – GROUP 06 SOLID FUEL GRATE ASSY	0031 00
REPAIR PARTS AND SPECIAL TOOLS LIST – GROUP 07 REAR DOOR	0032 00
REPAIR PARTS AND SPECIAL TOOLS LIST – GROUP 08 BURNER COVER ASSY	0033 00
REPAIR PARTS AND SPECIAL TOOLS LIST – GROUP 09 DOWN TUBE ASSY	0034 00
REPAIR PARTS AND SPECIAL TOOLS LIST – GROUP 10 BURNER CLEANING TOOL	0035 00
REPAIR PARTS AND SPECIAL TOOLS LIST – GROUP 11 FUEL HOSE KIT	0036 00
REPAIR PARTS AND SPECIAL TOOLS LIST – GROUP 12 GRAVITY FEED ADAPTOR	0037 00
BULK MATERIAL REPAIR PARTS LIST	0038 00
NATIONAL STOCK NUMBER INDEX	0039 00
SPECIAL TOOLS LIST	0040 00
PART NUMBER INDEX	0041 00
COMPONENTS OF END ITEM (COEI) LIST & BASIC ISSUE ITEMS (BII) LIST	0042 00
ADDITIONAL AUTHORIZATION LIST	0043 00
EXPENDABLE AND DURABLE ITEMS LIST	0044 00
MANDATORY REPLACEMENT PARTS LIST	0045 00

ALPHABETICAL INDEX..... INDEX 1

THIS PAGE INTENTIONALLY LEFT BLANK

TM 10-4520-261-12&P

HOW TO USE THIS MANUAL

This Manual contains General Information, Operating Instructions, Operator Preventive Maintenance Checks and Services (PCMS), Troubleshooting, and Maintenance/Repair instructions for the Space Heater Arctic (SHA).

Chapter 1 contains introductory information on the SHA and its associated equipment as well as a Theory of Operation. Chapter 2 includes operating instructions under usual and unusual conditions. Chapter 3 contents include operator troubleshooting, PMCS, and service procedures. Chapter 4 contains Unit Maintenance instructions. Chapter 6 contains references and other supporting information. Chapter 6 also includes the Repair Parts and Special Tools List (RPSTL) which identifies those parts or tools which are unique to the operation and maintenance of this equipment.

Manual Organization and Page Numbering System. The Manual is divided into six major chapters that detail the topics mentioned above. Within each chapter are work packages covering a wide range of topics. Each work package is numbered sequentially starting at page 1. The work package has its own page numbering scheme and is independent of the page numbering used by other work packages. Each page of a work package has a page number of the form XXXX YY-ZZ where XXXX is the work package number (e.g. 0010 is work package 10) and YY is the revision number for that work package and ZZ represents the number of the page within that work package. A page number such as 0010 00-1/2 blank means that page 1 contains information but page 2 of that work package has been intentionally left blank.

Finding Information. The Table of Contents permits the reader to find information in the manual quickly. The reader should start here first when looking for a specific topic. The Table of Contents lists the topics contained within each chapter and the Work Package Sequence Number where it can be found.

Example: If the reader were looking for instructions on "Preventive Maintenance Checks and Services", which is a Operator Maintenance topic, the Table of Contents indicates that Operator Maintenance information can be found in Chapter 3. Scanning down the listings for Chapter 3, "Preventive Maintenance Checks and Services" information can be found in WP 0010 00 (i.e. Work Package 10).

An Alphabetical Index can be found at the back of the Manual, and lists specific topics with the corresponding work package.

THIS PAGE INTENTIONALLY LEFT BLANK

CHAPTER 1
INTRODUCTION
TO SPACE HEATER ARCTIC
(SHA)

THIS PAGE INTENTIONALLY LEFT BLANK

**SPACE HEATER ARCTIC (SHA)
GENERAL INFORMATION**

0001 00

SCOPE

This Technical Manual contains instructions for the operation as well as preventive and corrective maintenance for the Space Heater Arctic (SHA) (1) and its associated components consisting of a Fuel Flow Control Valve (2), Nested Stack Assembly (3), Fuel Supply Hose (4), Fuel Overflow Hose (5), Solid Fuel Grate (6), Cleaning Tool (7), Stack Cap (8), Gravity Feed Adaptor (9), Fuel Can Stand (optional, refer to AAL) (10) and Thermolectric Fan (optional, refer to AAL) (11). The SHA is fielded as a safe and versatile heat source for the Army=s field operations.

Type of Manual: Operator=s and Unit Maintenance.

Model Number and Equipment Name: Space Heater Arctic (SHA), NSN 4520-01-444-2375

Purpose of Equipment: The SHA provides heat in a range from 15,000 to 25,000 BTU/hour. It is designed to be used in small to medium size shelters in moderate to arctic conditions. The SHA operates with various types of liquid or solid fuel.

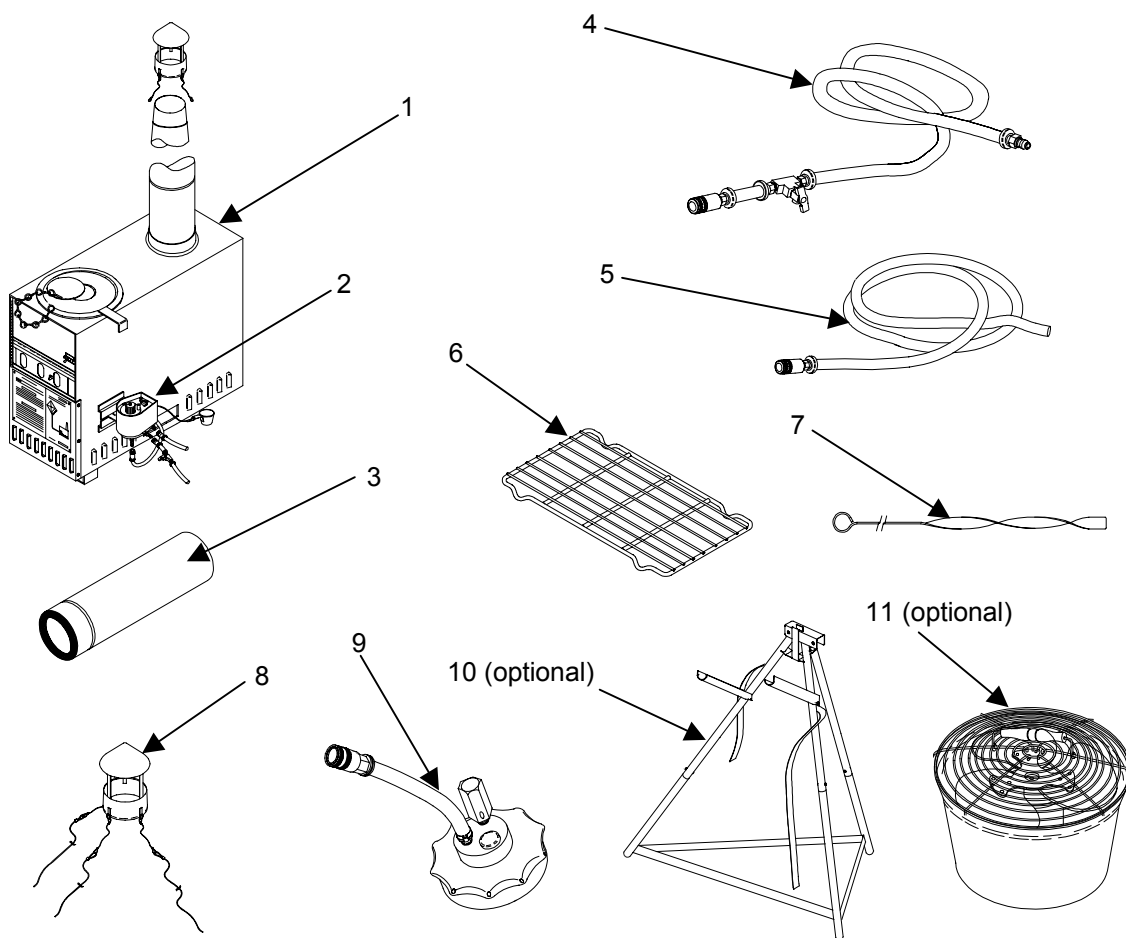

MAINTENANCE FORMS RECORDS AND REPORTS.

Department of the Army forms and procedures used for equipment maintenance will be those prescribed by DA PAM 738-750, Functional Users Manual for The Army Maintenance Management System (TAMMS) (Maintenance Management Update).

REPORTING EQUIPMENT IMPROVEMENT RECOMMENDATIONS (EIRs).

If your SHA needs improvement, let us know. Send us an EIR. You, the user are the only one who can tell us what you don't like about your equipment. Let us know why you don't like the design or performance. Put it on an SF368 Product Quality Deficiency Report. Mail it to: Commander U.S. Army Soldier and Biological Chemical Command; ATTN: AMSSC-I-LO, Kansas St. Natick MA 01760-5052. We will send you a reply.

CORROSION PREVENTION AND CONTROL (CPC).

Corrosion Prevention and Control (CPC) of Army materiel is a continuing concern. It is important that any corrosion problems with this item be reported so that the problem can be corrected and improvements can be made to prevent the problem in future items.

While corrosion is typically associated with rusting of metals, it can also include deterioration of other materials, such as rubber or plastic. Unusual cracking, softening, swelling or breaking of these materials may be a corrosion problem.

If a corrosion problem is identified, it can be reported using SF 368, Product Quality Deficiency Report. Use of key words such as *Acorrosion*, *Arust*, *Adeterioration* or *Acracking* will ensure that the information is identified as a CPC problem. This form should be submitted to the address specified in DA Pam 738-750.

DESTRUCTION OF ARMY MATERIEL TO PREVENT ENEMY USE.

For procedures to destroy this equipment to prevent its use by the enemy, refer to TM 750-244-2, Procedures for Destruction of Material to Prevent Enemy Use.

NOMENCLATURE CROSS-REFERENCE LIST.

Common Name	Official Name
SHA	Space Heater Arctic
Fuel Adjustment Knob	Metering Knob
Fuel Selector Switch	Fuel Switch
Fuel Flow Control Valve	Fuel Flow Control

LIST OF ABBREVIATIONS/ACRONYMS.			
AAL	Additional Authorization List	lt	Liter
BII	Basic Issue Item	MSDS	Material Safety Data Sheet
COEI	Component of end item	MTOE	Modified Table of Org and Equipment
CPC	Corrosion Prevention Control	NBC	Nuclear, Biological, Chemical
cm	Centimeter	POL	Petroleum, Oil and Lubricant
°C	Degrees Celsius	QD	Quick Disconnect
°F	Degrees Fahrenheit	RPSTL	Repair Parts and Special Tools List
EIR	Equipment Improvement Recommendation	TMDE	Test, Measurement, Diagnostic Equipment
gal	Gallons	TOE	Table of Organization and Equipment
hr	Hour	U/M	Unit of Measure
IAW	In Accordance With	UOC	Usable On Code
in	Inches	WP	Work Package
Kg	Kilogram		
lbs	Pounds		

SAFETY, CARE AND HANDLING, WARNINGS, CAUTIONS AND NOTES.

Always pay attention to Warnings, Cautions and Notes appearing throughout the manual. They will appear prior to applicable procedures. Ensure you read and understand their content to prevent serious injury to yourself and others, or damage to equipment.

EQUIPMENT CHARACTERISTICS, CAPABILITIES AND FEATURES.

CHARACTERISTICS	CAPABILITIES AND FEATURES
! Multipurpose	Operable with: Liquid Fuels: JP-5, JP-8, Diesel (DF-A, DF-1, DF-2), Kerosene, Jet-A Solid Fuels (Coal, Wood) SHA operates at 15,000 to 25,000 BTU/hour output
! Portable	
! Self-contained	
! Lightweight	
! Liquid and Solid Fuels	
! Food Warmer	
! Combustion by-products vented outside	

THIS PAGE INTENTIONALLY LEFT BLANK

LOCATION AND DESCRIPTION OF MAJOR COMPONENTS

LOCATION AND DESCRIPTION OF MAJOR COMPONENTS

Stack cap assembly (1). The Stack Cap Assembly is installed on the top of the nested stack assembly (4) to prevent down-drafts from entering the heater during operation. It also prevents rain, leaves, and other debris from entering the stack assembly. Guy lines (2), secured to three wire ropes (3), lead to ground stakes that stabilize the entire stack assembly (4) in an upright (vertical) position during heater operation.

Nested stack assembly (4). Consists of six pipe sections (middle sections not shown) of decreasing diameter. When assembled, the sections form a cone-shaped stack with the largest diameter section at the base and the smallest diameter at the top. Each section is flanged on its smaller end in order to fit into the next higher section. The assembly (4) seats in the stack adaptor assembly (5), allowing combustion gases to discharge outside the tent during operation. When disassembled, the sections fit inside each other for storage in the upper portion of the heater body (6).

Heater body assembly (6). Basic shell of the heater.

Lid assembly (7). The lid assembly (7) fits into a circular opening on the top surface of the heater. The built-in sight glass (8) allows the user to monitor the burner flame. It also permits access to the burner down tube assembly (9) when igniting liquid fuel. The lid assembly (7) is stored in the upper portion of the heater body (15).

Door assembly (10). Hinged door is secured with a slide latch. When opened, it allows access to install and remove the solid fuel grate (11) and burner cover assembly (12). It permits adding and igniting fuel in solid fuel operation. A built-in sliding draft gate (13) allows burn rate control during solid fuel operation only.

Burner cover assembly (12). During solid fuel operation, this cover (12) is positioned on top of burner shell (18) to prevent ashes, coals, and embers from falling into the burner shell. During liquid fuel operation, the cover (12) is positioned in the frame of the door assembly, and held in position by the closed door (10), to achieve a tight air seal.

Solid fuel grate (11). Elevates solid fuel while it burns to allow for air circulation and to provide an area for ash deposits. The Solid Fuel Grate MUST be removed prior to liquid fuel operation.

Rear door (14). The Rear Door fits on the rear of the heater and acts to contain the parts which may be stored in the storage enclosure (15) while the heater is not in use.

Rear storage enclosure (15). Accessed through the rear door (14) and used to stow all loose parts that will not fit inside the heater body during transport of the heaters. Items stored in this area include the Fuel Flow Control Valve (16), Stack Cap Assembly (1), and Gravity Feed Adaptor (26).

Burner shell assembly (17). Area of combustion in liquid fuel mode. Consists of a perforated burner shell (18), high fire ring (19), and up-tube (20) which is welded into the base of the burner shell (18). It permits fuel vapors to flow into the down-tube assembly (9) during operation.

Down-tube assembly (9). A capped down tube which is positioned on the up-tube (20) and removable through the lid assembly (7). A superheater ring is located on the exterior for heat transfer. During operation, fuel flows into the up-tube (20) where its level is gravity-maintained with the fuel flow control

LOCATION AND DESCRIPTION OF MAJOR COMPONENTS

valve (16). Fuel vaporizes due to combustion heat and fuel vapor is expelled from the up-tube (20), down through the down tube and into the burner shell (18) where it ignites. The down-tube (9) and up-tube (20) are cleaned with the reaming tool (21), which is kept inside the heater body during storage (15). The reaming tool (21) should be stored in an accessible yet protected location when not in use.

Fuel flow control valve (16). Mounts to a “T” shaped bracket (22) and slides into position on the right side of the heater body (6). The valve (16) functions safely with the liquid fuels specified in this work package. When set properly, internal orifices match the viscosities of the fuels being used to meter the correct fuel flow to the burner. The cup/cable assembly (23) is attached to the bracket and is used for measuring fuel to prime the heater in liquid fuel mode.

Fuel can stand, collapsible (24) (optional item). Allows the fuel can (25) to be mounted in an inverted position to permit gravity fuel feed to the fuel flow control valve (16). (Note: The Fuel Can Stand is available as an Additional Authorized Item as detailed in WP 0045).

Gravity feed adaptor (26). Threads onto fuel can (25). Hose (27) allows fuel flow from the fuel can (25) during operation. The automatic vent (28) permits air to vent into the can for proper fuel flow to the heater.

Fuel hoses (29)(30). Fuel supply hose (29) allows fuel flow from fuel can (25) through the gravity feed adaptor (26) to the fuel flow control valve (16), through the hose to the burner up-tube (20). An overflow hose (30) drains fuel outside the tent in the event of a malfunction of the Fuel Flow Control Valve (16). Hoses, (29) and (30), connect with quick-disconnect couplings. The fuel control outflow hose (31) delivers fuel from the control valve to the burner assembly. The fuel supply hose (29) and overflow hose (30) are both stored in the upper portion of the heater body (15).

SPACE HEATER ARCTIC (SHA)

LOCATION AND DESCRIPTION OF MAJOR COMPONENTS

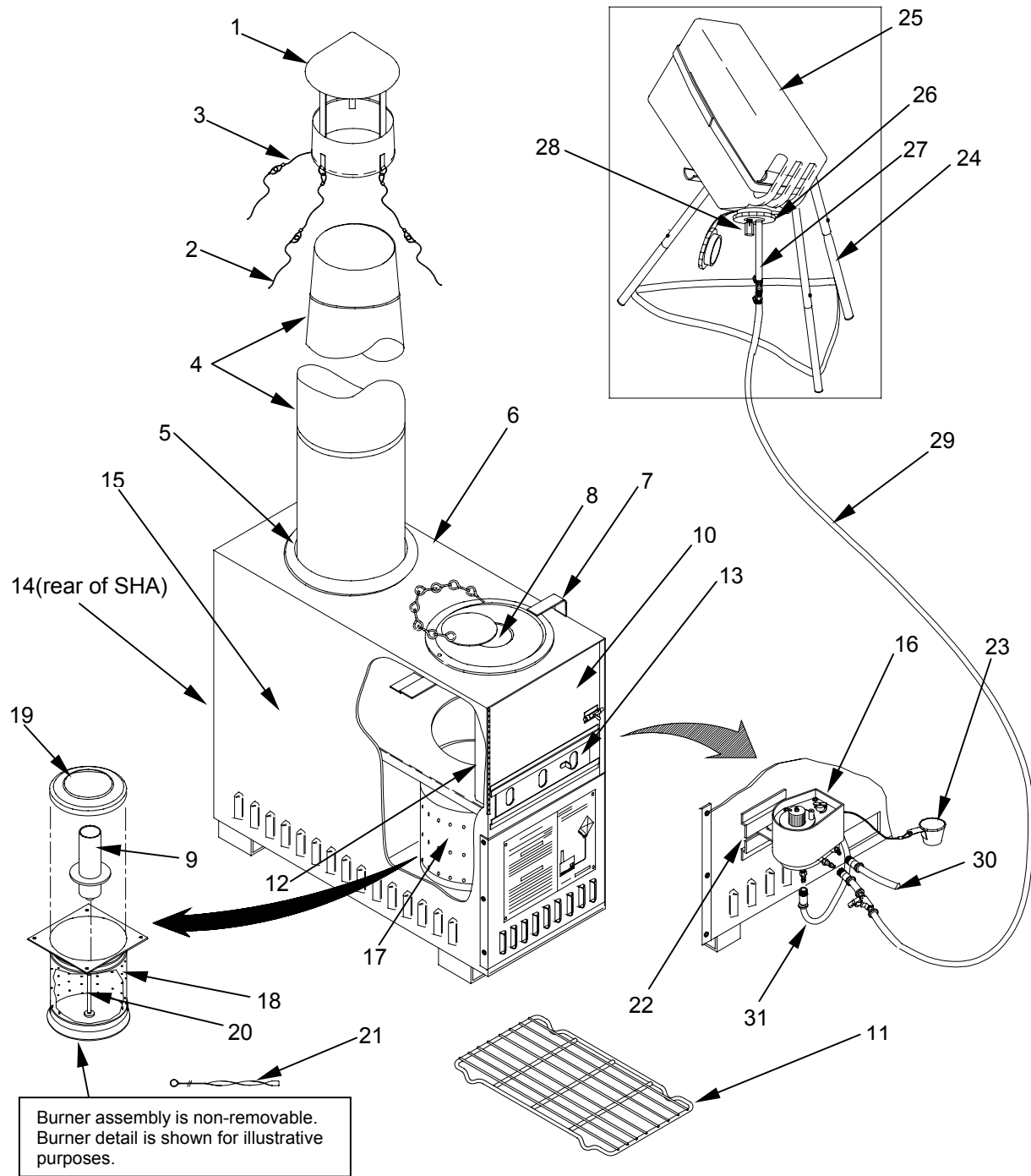

LOCATION AND DESCRIPTION OF MAJOR COMPONENTS

DESCRIPTION OF SYSTEM COMPONENTS

The associated components of the SHA are illustrated and described below:

Fuel Supply Hose. Connects between the fuel can gravity feed adaptor and the fuel flow control valve. Supplies fuel to the SHA. A "T" connector with petcock permits fuel to be drained off into the measuring cup for priming.

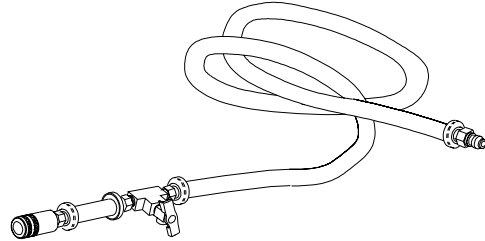

Fuel Overflow Hose. Connects to the Fuel Flow Control Valve and allows any overflow fuel to be sent outside the shelter.

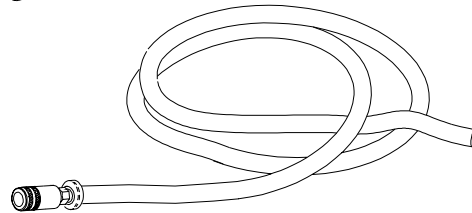

Fuel Can Stand (optional item). The Fuel Can Stand supports a standard plastic fuel can in an inverted position in order to gravity feed fuel to the heater. The stand disassembles and folds for packing. (Note: The fuel can stand is an optional item and is available as an Additional Authorized Item as detailed in WP 0045).

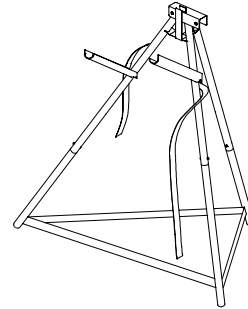

Adapter, Gravity Feed. This adapter installs in a standard issue plastic fuel can and permits fuel to flow by gravity from the fuel can to the SHA.

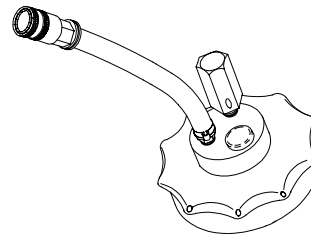

Fan, Thermoelectric (optional item). The Thermoelectric Fan generates its own power from the heat generated by the SHA and is placed on the top of the SHA Lid Assembly. (Note: The fan is available as an Additional Authorized Item as detailed in WP 0045.)

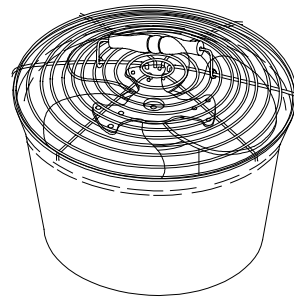

LOCATION AND DESCRIPTION OF MAJOR COMPONENTS

EQUIPMENT DATA

The following technical and identification data pertains to the SHA and selected support equipment.

Equipment Specification Data

Table 1. Equipment Data

WEIGHT:	
SHA.....	41 lbs (18.6 Kg)
DIMENSIONS:	
Height.....	17 in (43.2 cm)
Width.....	9 in (22.9 cm)
Depth.....	17.5 in (44.4 cm)

Performance Specification Data.



WARNING!
Fire or Explosion

Do not use gasoline, used motor oil, cleaning solvents, or any other fuel not authorized for use in the SHA. Use of an unauthorized fuel may result in fire or explosion.

FUEL TYPES USABLE FOR HEATER OPERATION:

Liquid Fuel Mode.....JP-5, JP-8, Diesel (DF-A, DF-1, DF-2), Kerosene, Jet A
Solid Fuel Mode..... Wood, Coal

LIQUID FUEL CONSUMPTION:

Rate of fuel consumption at maximum firing rate:

DF-1, DF-2..... 1/3 gal /hr (15 hours operation on 5 gal can)
JP-5, JP-8, DF-A..... 1/3 gal /hr (15 hours operation on 5 gal can)

OUTPUTS:

Heater Burn Rate (setting dependent) 15,000 to 25,000 BTU/hr

ENVIRONMENTAL:

Operating temperatures -60°F to +50°F (-51°C to +10°C)
Operating elevations to 6,000 ft above sea level

COMMON TOOLS AND EQUIPMENT

For authorized common tools and equipment, refer to the Modified Table of Organization and Equipment (MTOE), CTA 50-970, Expendable/Durable Items (Except: Medical, Class V, Repair Parts, and Heraldic Items), or CTA 8-100, Army Medical Department Expendable/Durable Items, as applicable to your unit.

All Special Tools, TMDE, and Support Equipment for the SHA are listed in WP 0042.

Repair parts are listed and illustrated in the repair parts and special tools list located in work packages 0026 through 0043.

THEORY OF OPERATION

General. The Space Heater Arctic (SHA) can operate using either liquid or solid fuel. In liquid fuel mode, the heater requires an external supply of gravity-fed fuel. In solid fuel mode, the heater operates independently of outside equipment on a regularly maintained supply of wood or coal. When using liquid or solid fuel, combustion gases are exhausted out the roof of the shelter through the stack assembly.

The heater has variable heat output, and can be controlled by the operator. During liquid fuel operation, heat output is controlled with the fuel flow control valve. When operating with solid fuel, the heat output is controlled using the draft gate and by controlling the supply of fuel.

During normal operation, and with proper burn rate control, the heater will produce an even, yellow-colored flame. The SHA will not emit smoke or other combustion gases into the space being heated. Proper safety precautions should be maintained in the area surrounding the heater as the entire unit will be hot during operation.

The SHA requires minimal maintenance which includes the removal of ash deposits during and after operation in solid fuel mode as well as the periodic wipe out of the burner shell. Refer to the Preventive Maintenance Checks and Services as detailed in work package 0010 for more information.

LIQUID FUEL OPERATION



CAUTION!

All components in the storage enclosure must be removed during operation. Components remaining inside the storage compartment could be damaged by high heat.

Gravity-fed liquid fuel (refer to work package 0001 for a list of authorized fuels) flows from the inverted fuel can **(1)** through fuel hoses to the fuel flow control valve **(2)**. Fuel settings are made on the fuel flow control valve **(2)** based on the temperature of the fuel being used. Fuel is directed through internal orifices and then flows into the burner up-tube **(3)** inside the burner shell assembly **(4)**.

With access through the lid opening **(5)**, a small amount of fuel is poured and ignited in the bottom of the burner shell assembly **(4)**. A burning piece of fuel-dampened tissue is placed at the bottom of the burner shell assembly **(4)** with the help of the reamer tool **(6)**. After five to ten minutes, enough heat is produced by the burning priming fuel to vaporize fuel within the up-tube **(3)**. Fuel vapors are generated and are discharged into the downtube **(7)**, where it enters the burner shell assembly **(4)**, mixes with air, and is combusted. By the time all the priming fuel is consumed, the combustion process has been established and will continue as long as there is fuel in the fuel can **(1)** or the Fuel Flow ON/OFF control of the Fuel Flow Control Valve **(2)** is in the ON position.

Air, required for combustion, is drawn through the bottom of the heater and into the burner shell assembly **(4)**. The burner cover **(8)** is set into the door frame (only in liquid fuel mode), and the door **(9)** shut and latched. This prevents air leakage into the upper heater body while the heater is in use which would impair operating efficiency.

The flame is monitored through the sight glass (10) on the lid assembly (5). Combustion gases pass from the burner shell assembly (4) through the upper heater body, through the stack adaptor assembly (11), up through the telescopic stack assembly (12), and outside the shelter through the stack cap assembly (13).

Heat output is controlled by positioning the fuel flow adjustment knob (14) of the fuel flow control valve (2), limiting the amount of fuel sent to the burner shell assembly (4) for combustion.

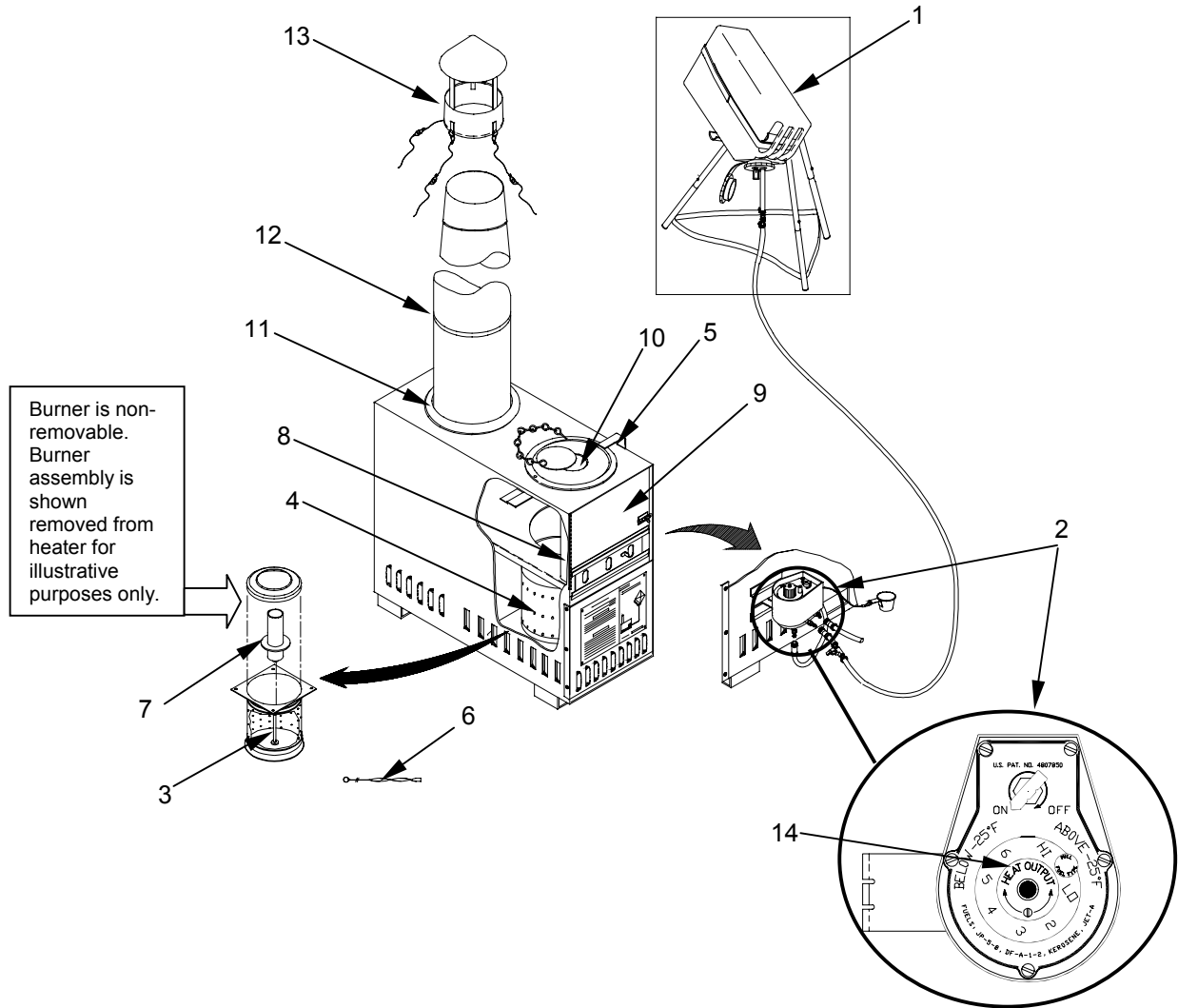

SOLID FUEL OPERATION**CAUTION!**

All components in the storage enclosure must be removed during operation. Components remaining inside the storage compartment could be damaged by high heat.

**CAUTION!**

Do not overfill the heater when using coal as a solid fuel. Coal is very dense and produces a very high heat output. Using too much coal in the heater will overfire the unit and make it very difficult to control the heat output.

The burner cover **(1)** is set over the burner shell assembly **(2)** and prevents ashes, coals, and embers from collecting in the burner shell assembly **(2)** during operation. Paper and small pieces of fuel (kindling) are positioned and ignited with a match on the solid fuel grate **(3)**, which elevates the fuel to ensure proper air circulation, and allows a space for falling ash to accumulate. When the kindling begins to burn steadily, larger pieces of wood or coal are added to increase heat output.

The flame is monitored through the sight glass **(4)**. Combustion gases flow through the stack adaptor assembly **(5)**, up the telescopic stack assembly **(6)**, and through the stack cap assembly **(7)** to the outside of the shelter.

Heat output is controlled by the amount of fuel placed in the heater and the positioning the sliding draft gate **(8)**, which controls air intake.

Care should be used in determining the amount of solid fuel to be placed in the heater. Coal is a very dense fuel and will provide very high heat output. A small amount of coal should be used to start the heater. Do not overfill the heater with coal as it may over fire the unit and make it very difficult to control the heat output.

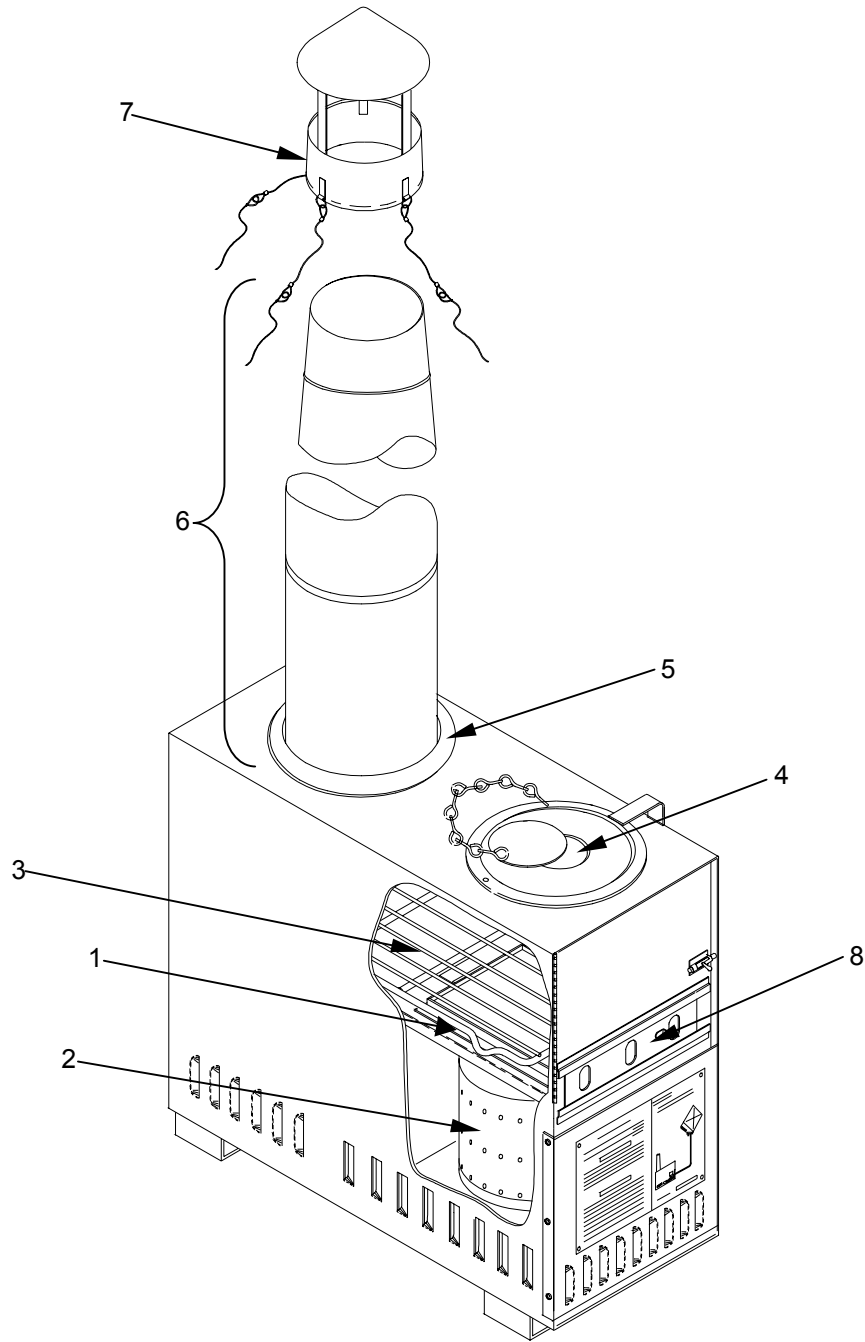

CHAPTER 2
OPERATING INSTRUCTIONS
FOR
SPACE HEATER ARCTIC

THIS PAGE INTENTIONALLY LEFT BLANK

**SPACE HEATER ARCTIC (SHA)
CONTROLS, INDICATORS, AND LABELS/INSTRUCTION PLATES**

GENERAL

The following illustrations and tables show the location and function of each control and indicator on the SHA and its associated equipment. Table 1 describes the controls and indicators for the SHA.

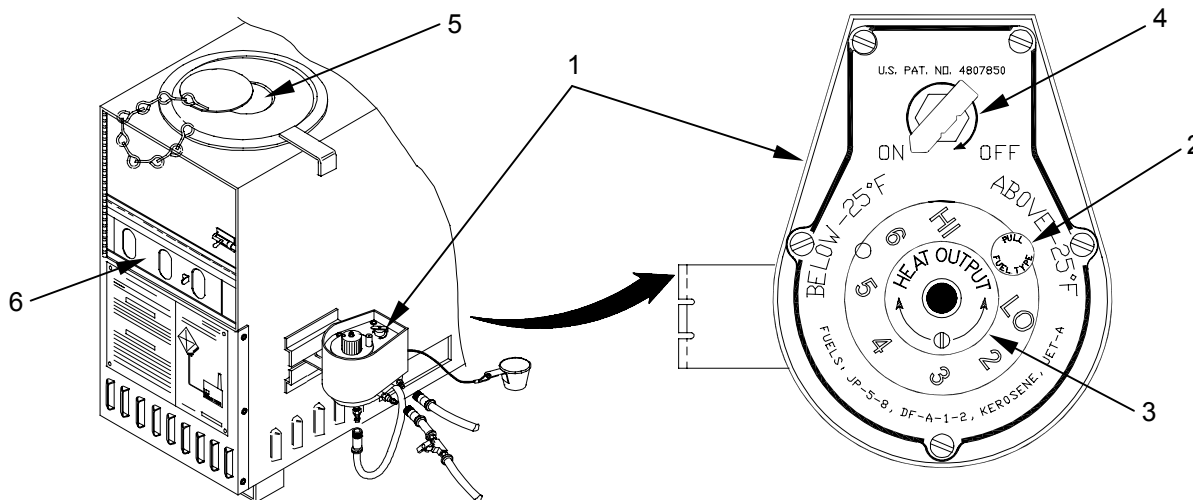

Table 1. SHA Controls and Indicators

KEY	ITEM	FUEL MODE	FUNCTION
1	FUEL FLOW CONTROL VALVE	Liquid	Controls fuel flow to burner.
2	FUEL SELECTOR CONTROL	Liquid	<p>Sets fuel flow control for ambient temperature. This is done by pulling up knob and rotating it to the proper temperature setting.</p> <p>Contains the following settings:</p> <p>ABOVE 25⁰F This setting is for all authorized liquid fuels (refer to WP 0001) when used above -25⁰F (-32⁰C)</p> <p>BELOW 25⁰F This setting is for all authorized liquid fuels (refer to WP 0001) when used below -25⁰F (-32⁰C)</p>
3	FLOW ADJUSTMENT KNOB	Liquid	Controls fuel flow from float chamber to burner.
4	FUEL ON/OFF CONTROL	Liquid	Controls fuel flow from fuel supply to fuel flow control valve.
5	LID ASSEMBLY SIGHT GLASS	Solid or liquid	Allows viewing of flame in burner.
6	SLIDING DRAFT GATE	Solid	Controls heat output by limiting amount of air flow into burner when using solid fuel only. Burner Plate is in position when using liquid fuel.

FUEL SUPPLY AND OVERFLOW HOSES

Table 2 describes the controls and indicators for the Fuel Supply and Overflow hoses.

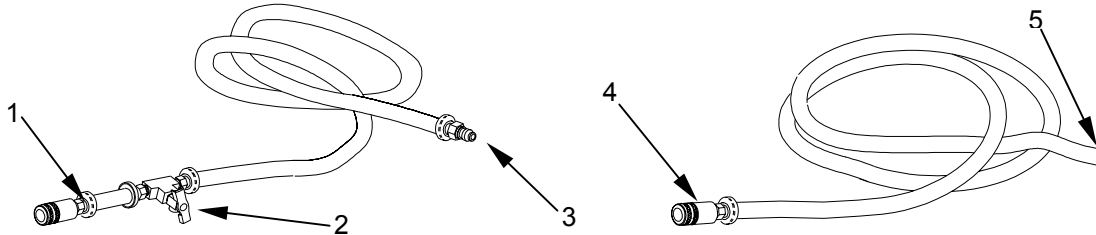

Table 2. Fuel Supply and Overflow Hose Controls and Indicators

KEY	CONTROL AND INDICATOR	FUNCTION
1	Female QD Connector fuel supply hose	Connects fuel supply to Fuel Flow Control Valve
2	"T" connector with petcock	Permits fuel to be drained into cup for priming
3	Male QD connector fuel supply hose	Connects fuel supply hose to fuel can gravity feed adapter
4	Female QD connector fuel overflow hose	Connects to Fuel Flow Control Valve to permit excess fuel to drain
5	Open end of fuel overflow hose	Placed outside of shelter on downslope to permit any overflow fuel to drain

FUEL CAN STAND (OPTIONAL) AND GRAVITY FEED ADAPTER

Table 3 describes the controls and indicators for the Fuel Can Stand. (The fuel can stand is available as an Additional Authorized Item as detailed in WP 0045.)

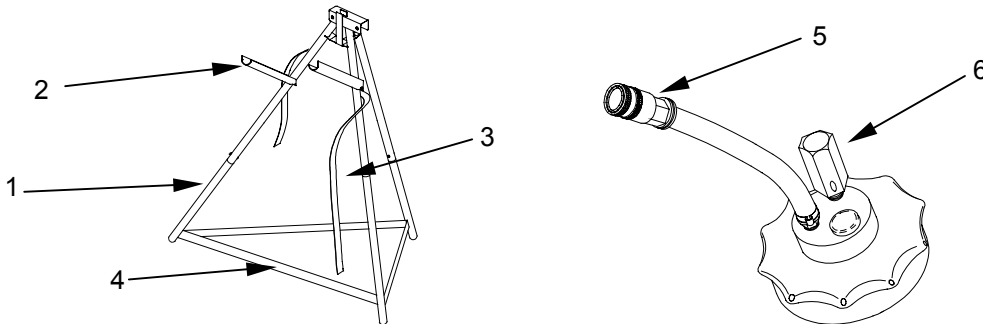

Table 3. Fuel Can Stand (optional) and Gravity Feed Adapter Controls and Indicators

KEY	CONTROL AND INDICATOR	FUNCTION
1	Fuel Can Stand Leg Assembly	Provides stable tripod to support fuel can
2	Fuel Can Supports	Supports fuel can when in feed position
3	Fuel Can Strap	Straps fuel can to stand
4	Fuel Can Stand Stabilizer Straps	Permits proper spacing of fuel can stand leg assembly
5	Gravity Feed Adaptor Female QD Connector	Connects fuel supply to fuel supply hose
6	Gravity Feed Adaptor Automatic Vent Valve	Allows air to vent into fuel can, permitting proper fuel flow

LABELS AND INSTRUCTION PLATES

The following labels and instruction plates are found on the SHA components as indicated.

SHA Front Panel

OPERATING INSTRUCTIONS.

1. SEE HEATER TECHNICAL MANUAL FOR DETAILED INSTRUCTIONS
2. FOR WOOD OR COAL USE, SEE TECHNICAL MANUAL.

DANGER

DO NOT USE GASOLINE OR JP4 IN THIS UNIT

3. NEVER ATTEMPT TO RE-LIGHT BURNER WHILE IT IS HOT. WAIT UNTIL IT HAS COOLED.
4. LIGHTING INSTRUCTIONS USING AUTHORIZED FUELS (DIESEL, D1, D2, JP-5, JET A, KEROSENE OR DFAX ROTATE SELECTOR PIN ON VALVE TO MATCH OUTSIDE TEMPERATURE.)
TURN VALVE SHUTOFF KNOB TO "ON".
TURN VALVE CONTROL KNOB TO HI AND WAIT 2-5 MINUTES. POUR ONE CUP OF FUEL INTO BASE OF BURNER (TWO CUPS IF TEMPERATURE IS -25°F OR BELOW).
IGNITE PRIMING FUEL WITH LIGHTED TISSUE PAPER.

WARNING

KEEP HANDS AND FACE AWAY FROM LID OPENING TO PREVENT BURNS
CLOSE LID - WAIT FOR BURNER TO WARM UP AND THEN ADJUST TO REQUIRED FLOW RATE.

5. NEVER OVERFIRE. NO SMOKE SHOULD BE SEEN FROM THE STACK.
6. REPAIR ALL LEAKS. BE SURE OVERFLOW LINE IS SLOPED DOWNWARD, TO OUTSIDE OF TENT. IF FUEL FLOWS FROM THE OVERFLOW, REPLACE THE VALVE.

MANUFACTURED BY HUNTER MFG CO.
UNDER EXCLUSIVE LICENSE WITH
INTERNATIONAL THERMAL RESEARCH LTD.
PATENT NO'S 5,759,024 & 5,527,180

HUNTER
Hunter Manufacturing Company
30525 Aurora Road
Solon, OH, 44139
WWW.hunterheater.com
SHA HEATER ASSY, P/N: 92878-106365
NSN: 4520-01-444-2375

Fuel Flow Control Valve

**CONTROL FUEL
FLOW FOR THE
SPACE HEATER ARCTIC**

U.S. PROD. DATE
MANUFACTURED BY:

CAUTION
DO NOT ATTEMPT TO
RELIGHT BURNER AFTER
FLAME FAILURE UNTIL
COMBUSTION CHAMBER HAS
COOLED AND IS FREE OF
VAPORIZED FUEL

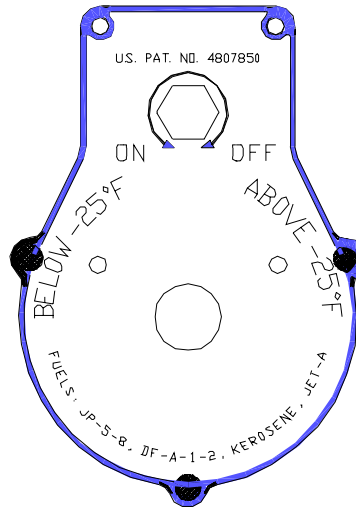

Thermoelectric Fan Labels (Optional Equipment, Refer To WP 0045)

THERMOELECTRIC FAN (TEF)
THIS FAN IS INTENDED TO CIRCULATE THE AIR AROUND A HEATER TO IMPROVE COMFORT AND REDUCE FUEL CONSUMPTION. IT DOES NOT REQUIRE EXTERNAL POWER. TO OPERATE, SIMPLY REMOVE IT FROM THE STORAGE CASE AND PLACE ON A FLAT HORIZONTAL SURFACE OF OPERATING STOVE OR HEATER.

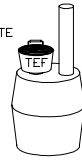

⚠ WARNING ⚠

DO NOT DROP. DO NOT INSERT FINGERS OR OTHER OBJECTS INTO FAN WHILE UNIT IS OPERATIONAL. PLACING HOT FAN ON A SURFACE CAN RESULT IN DAMAGE, FIRE OR INJURY.



THERMOELECTRIC FAN
Made in the USA by:
ASPEN SYSTEMS, INC.
Marlborough, Massachusetts
Model # TEF-III, Serial # _____

PREPARING THE SHA FOR OPERATION

SITING REQUIREMENTS



WARNING!

Two Person Lift

The SHA weighs approximately 40 pounds (18 kg). Two persons must carry the SHA when lifting or lowering the unit from 3 feet or more. Be sure to lift with legs, not back, to prevent injury.

This section outlines the siting requirements of the SHA, as well as the installation, preparation, and operation of the SHA under usual conditions.

Heat or sparks from stack assembly could ignite fuel supply. Set up fuel supply on a clear site seven feet (approx. 2.5 meters) from shelter and away from flame sources.

For safe operation, be sure to allow at least two (2) feet (61 centimeters) of space between the heater and the shelter wall.

Read all warnings and cautions within this section and follow procedures outlined herein to ensure safe operation of the SHA and associated equipment.

UNPACKING THE SHA SYSTEM COMPONENTS



CAUTION!

Do Not Leave Any Components Inside Heater Frame

All components stored in the storage compartment of the heater must be removed prior to operation. Components are stored in both the upper and lower portions of the heater. Most of these items are liquid fuel components which could be damaged by high heat if the heater is operated with solid fuel.

The Space Heater Arctic utilizes the area inside its shell for the storage of components during movement and storage. Some components are stored behind the front door while others are stored behind the rear door. Before the SHA can be used, all components must be removed from their respective storage areas.

To unpack the SHA, press down on the spring-tensioned Rear Door (1) and remove the Fuel Flow Control Valve (2), Stack Cap Assembly with Tent Lines (3), and Gravity Feed Adaptor (4).

**SPACE HEATER ARCTIC (SHA)
OPERATION UNDER USUAL CONDITIONS**

Reinstall the Rear Door (1) by placing the bottom edge of the door in the slot at the bottom of the heater frame. Press down on the door and swing it into position in the heater frame until the pin on the frame engages with the small slotted hole on the top edge of the rear door. Release the Rear Door.

Slide the front door latch (5) to the left and open the front door (6). Remove the Burner Cover Assembly if it is installed in the door frame.

Remove the Fuel Overflow Hose (7) (stored inside the Nested Stack Assembly), Fuel Supply Hose (8), Nested Stack Assembly (9), Burner Reaming Tool (10), Lid Assembly (11) and Solid Fuel Grate (12).

Install the Burner Cover Assembly (refer to next section for details). Close and latch the Front Door (6).

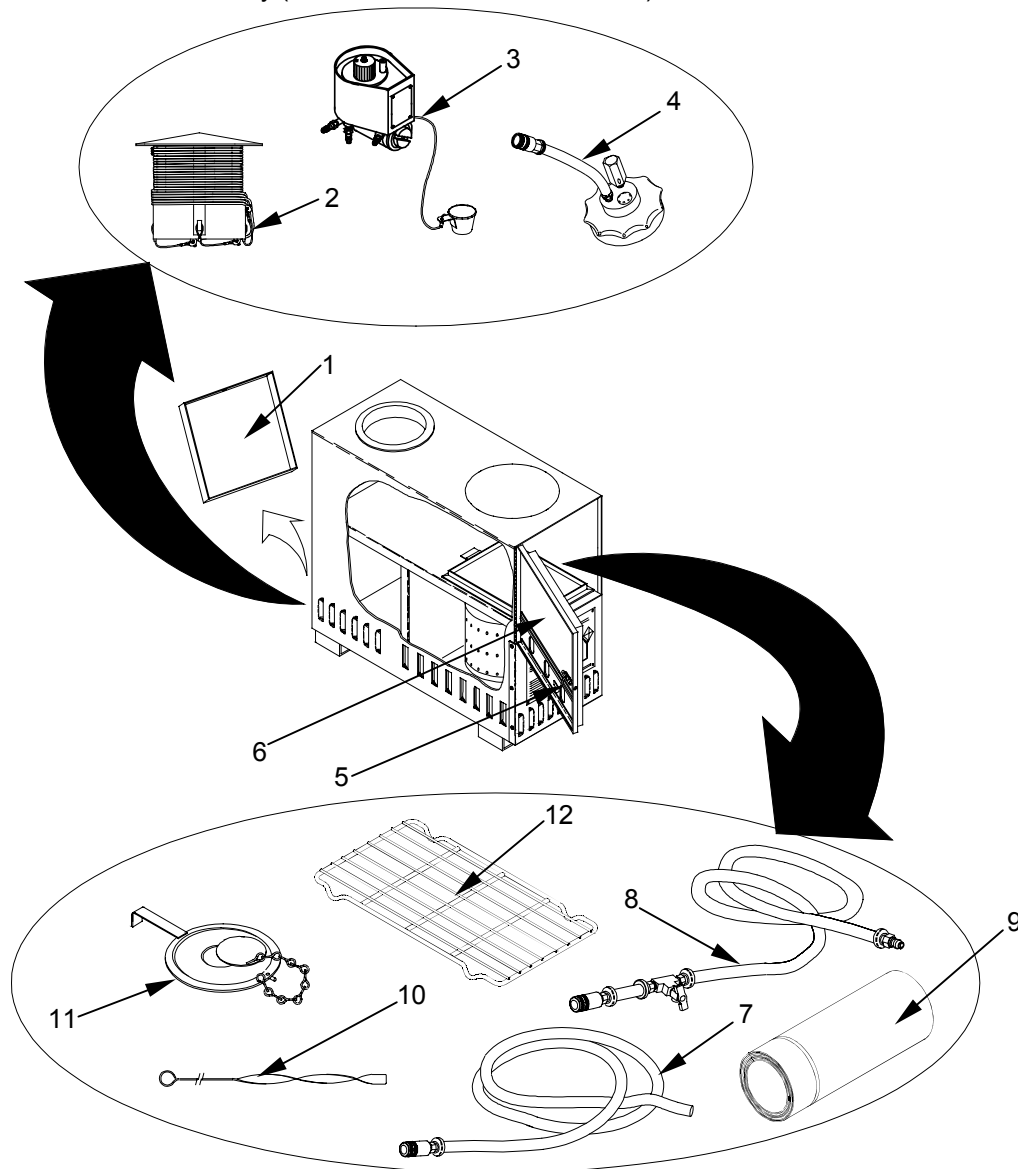

INSTALLING THE BURNER COVER ASSEMBLY AND SOLID FUEL GRATE

Before the SHA can be operated, the Burner Cover Assembly (1) must be installed according to the type of fuel being used.

When Operating the SHA in Liquid Fuel Mode

If the heater will be operated in Liquid Fuel mode, the Burner Door Assembly (1) must be installed in the door frame (2) located behind the Front Door (3). This is to prevent any air from entering through the front door of the heater. To verify proper installation of the Burner Cover Assembly, slide the front door latch (4) to the left and open the front door (3); ensure that the solid fuel grate (10) is not installed. The Burner Cover Assembly (1) must be installed in the door frame (2), blocking the area behind the front door (3). When the Burner Cover Assembly (1) is installed, close and latch (4) the front door (3).

When Operating the SHA in Solid Fuel Mode

When preparing to use the heater in solid fuel mode, the Burner Cover Assembly (1) should be installed over the Burner Assembly opening (5). To install the Burner Cover Assembly for solid fuel operation, slide the front door latch (4) to the left and open the Front Door (3). If the Burner Cover Assembly is currently installed in the door frame (2), remove it and allow it to hang from its retaining chain (6). If the Solid Fuel Grate (7) is installed, remove the grate and install the Burner Cover Assembly (1) smooth side down over the Burner Assembly opening (5). Slide the cover back toward the rear of the heater until its back edge (8) engages in the Burner Cover retaining clip (9). Install the Solid Fuel Grate (7) in position over the installed Burner Cover Assembly (1) making sure to install the grate with its feet (10) down on the deck (11) of the upper heater area.

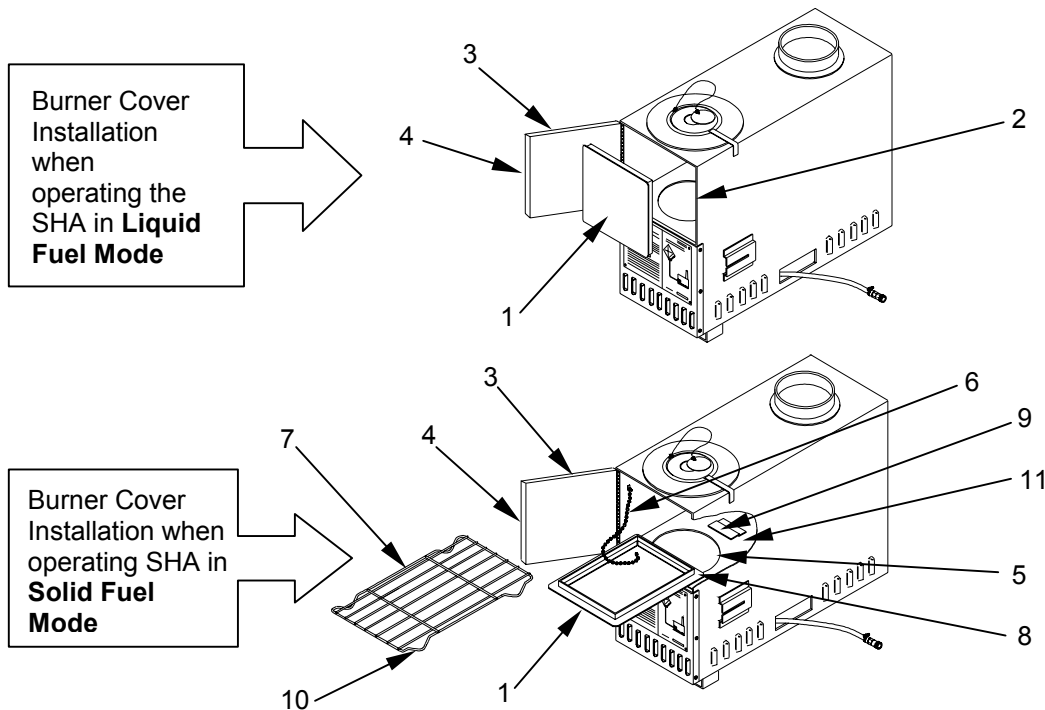



WARNING!
Fire or Explosion

Interchanging fuel flow control valves between various models of space heaters (e.g. Space Heater Arctic [SHA] and H-45 Large Radiant Space Heater) is not allowed! Operating a heater with an incorrect valve could result in fire or explosion!

Do not use unauthorized fuels! Use of unauthorized fuel may result in fire/explosion!

Shelter exhaust opening closure flap must be rolled and tied securely. Shelter may catch fire if hot stack assembly contacts the flap.

Poorly fitted stack sections may allow hot stack to fall on shelter and start a fire, or deadly carbon monoxide to leak into shelter. Ensure sections seat together fully.

Heat or sparks from stack assembly could ignite fuel supply. Set up fuel supply on a clear site seven feet (approx. 2.5 meters) from shelter and away from flame sources.

If fuel flow control valve assembly is improperly positioned or if bracket is bent, a fuel overflow could occur inside burner shell assembly and cause a fire or explosion.

For safe operation, be sure to allow at least one (2) feet (61 cm) of space between the heater and the shelter wall. Never relight a extinguished flame while the heater is hot. Be sure to allow the heater to cool completely before attempting to relight. Do not attempt to replenish the fuel supply while the heater is in operation. Be certain that there is no open flame in the vicinity of liquid fuel.

**WARNING!****Do Not Use Unauthorized Fuels**

Gasoline, JP-4, Used Motor Oil, Solvents or other unauthorized fuels should **NOT** be used with the SHA under any circumstance. **Only approved liquid and solid fuels may be used.** Using unauthorized fuels in the SHA will create a fire danger and potential for explosion.

**WARNING!****Carbon Monoxide**

During operation, the SHA produces harmful carbon monoxide (CO) and other gases. Carbon monoxide is a colorless, odorless, and tasteless gas. Mild cases of carbon monoxide poisoning can cause symptoms such as nausea, dizziness or headaches. Severe cases of carbon monoxide poisoning can result in brain damage, heart damage or death. Remember that although CO has no telltale odor, it may mix with other odors which mask its presence; therefore, CO can be present within a mix of seemingly harmless odors.

To prevent CO poisoning, ensure that the SHA exhaust stack sections fit together snugly and that the exhaust gases are properly vented through the roof of the shelter.

The best way to prevent CO poisoning is to keep the SHA in good working order. Ensure that all possible sources of CO leakage have been repaired and that the operating space is well ventilated.

**WARNING!****Hot Surfaces**

Do not attempt to handle or perform services on a heater that has recently been in operation. Let the heater cool down before performing these procedures to avoid the possibility of serious burns.

**WARNING!****Two Person Lift**

The SHA weighs approximately 40 pounds (18 kg). Two persons must carry the SHA when lifting or lowering the unit 3 feet or more. Be sure to lift with legs, not back, to prevent injury.

**WARNING!**
Cut Hazard

Some metal components of SHA may have sharp edges. Be careful when handling and assembling the SHA to prevent cuts.

**WARNING!**
Freeze Hazard

Severe injury may occur to personnel handling metal parts without protective gloves when temperatures are below freezing. Surface of skin may freeze upon contact and tear from the flesh.

Do not allow fuel to come in contact with bare skin. Even though fuel does not freeze, it is extremely cold and will burn exposed skin on contact. Wear protective gloves whenever handling or working with liquid fuel.

BEFORE OPERATION PMCS

Perform the "Before Operation PMCS" on all SHA system components as outlined in WP 0010, prior to preparing the heater for use. All scheduled maintenance must be performed on the heater and its associated equipment prior to use.

PREPARING AN AREA FOR THE SHA

Set up the heater inside its operating space (shelter). The area selected must be level and well-drained in event of wet weather, and free of debris and flammable materials. Two persons should transport the heaters to prevent injury.

SITE SETUP AND BASIC ASSEMBLY**WARNING!**
Fire or Explosion

Exhaust opening closure flap must be rolled and tied securely. Shelter may catch fire if hot stack assembly contacts the flap.

ASSEMBLING THE STACK ASSEMBLY

Outside the Shelter

Securely roll and tie exhaust opening closure flap (1) so it will not touch stack assembly during heater operation.

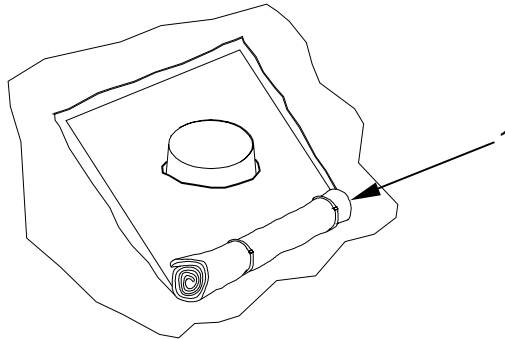

Inside the Shelter



WARNING!

Fire or Explosion

Allow at least 2 feet (61 centimeters) clearance between heater and shelter walls, or shelter fabric may catch fire.



CAUTION!

Do Not Leave Components Inside Heater Frame

All components stored in the storage compartment of the heater must be removed prior to operation. Components are stored in both the upper and lower portions of the heater. Most of these items are liquid fuel components which could be damaged by high heat if the heater is operated with solid fuel.

Set heater (2) directly under shelter exhaust opening (1).

If SHA components are still stored inside the heater, unpack all components and correctly install the Burner Cover Assembly as outlined earlier in this work package.

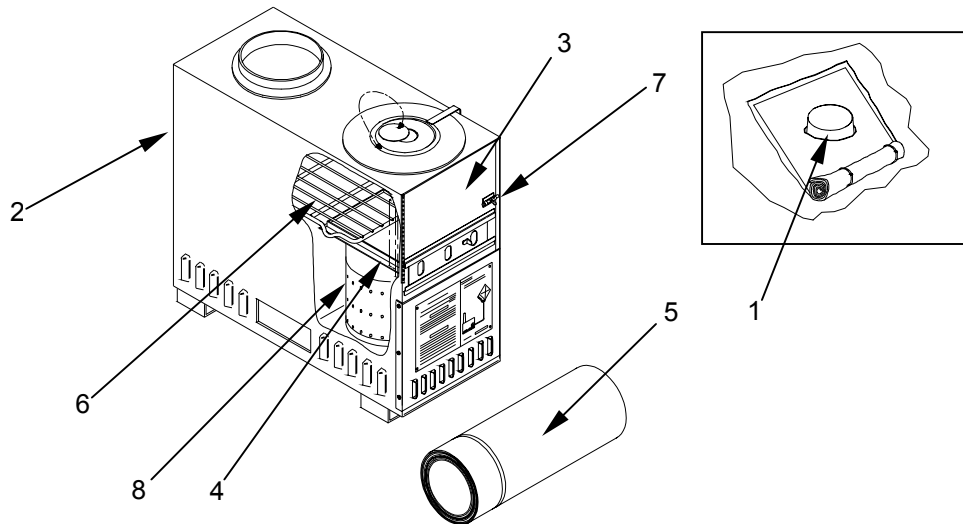

WARNING!
Fire Danger

Poorly fitted stack sections may allow hot stack to fall on shelter and start a fire, or deadly carbon monoxide to leak into shelter. Ensure sections seat together securely.



WARNING!
Carbon Monoxide

During operation, the SHA produces harmful carbon monoxide (CO) and other gases. Carbon monoxide is a colorless, odorless, and tasteless gas. Mild cases of carbon monoxide poisoning can cause symptoms such as nausea, dizziness or headaches. Severe cases of carbon monoxide poisoning can result in brain damage, heart damage or death. Remember that although CO has no telltale odor, it may mix with other odors which mask its presence; therefore, CO can be present within a mix of seemingly harmless odors.

To prevent CO poisoning, ensure that the SHA exhaust stack sections fit together snugly and that the exhaust gases are properly vented through the roof of the shelter.

The best way to prevent CO poisoning is to keep the SHA in good working order. Ensure that all possible sources of CO leakage have been repaired and that the operating space is well ventilated.

Tie one end of each shelter line **(1)** to each wire rope **(2)** on stack cap **(3)**. Set this assembly aside.

Unnest the stack assembly and assemble stack sections **(4-9)**, in order of decreasing size, onto the crimped end of each adjoining stack section. Each stack section is stamped on the side with a number. The largest diameter stack section is stamped "1" and installs in the heater body. The smallest diameter stack section is stamped "6" and is the topmost stack section. Lift the assembled exhaust stack **(10)** and pass it through the exhaust opening **(11)**.

Outside the Shelter

As the stack assembly passes through the exhaust opening **(11)**, have a person on the outside of the shelter install and fully seat the stack cap **(3)** with attached lines **(1)** onto topmost stack section **(4)**. Inside the shelter, raise the stack assembly and position the bottom stack **(9)** into the stack adaptor opening **(12)**. This completes the assembled exhaust stack **(10)**.

On the outside of the shelter, drive three stakes (not supplied with SHA) **(13)** into ground, positioned evenly apart and a minimum of six feet (1.83 meters) from the base of heater **(14)** as it is positioned inside the shelter.



WARNING! Fire Danger

It is important to stake the exhaust stack securely since this will keep the exhaust stack vertical and seated firmly within the stack adapter with a downward force. This also stabilizes the heater and helps prevent it from being knocked over if bumped by equipment or people inside the shelter. Secure staking assists in holding the shelter roof and sides in position during windy conditions. If the guy lines are improperly spaced and/or loose, the shelter roof and sides can flap during snowy, windy conditions. If the shelter itself is not taut, the roof and side walls can flap, getting quite close to the heater, creating a fire danger.

Making sure that the assembled exhaust stack **(10)** is positioned straight, tie the stack cap guy lines **(1)** securely to the stakes **(13)** to prevent it from swaying (be sure that the stack cap guy lines **(1)** are taut when complete).

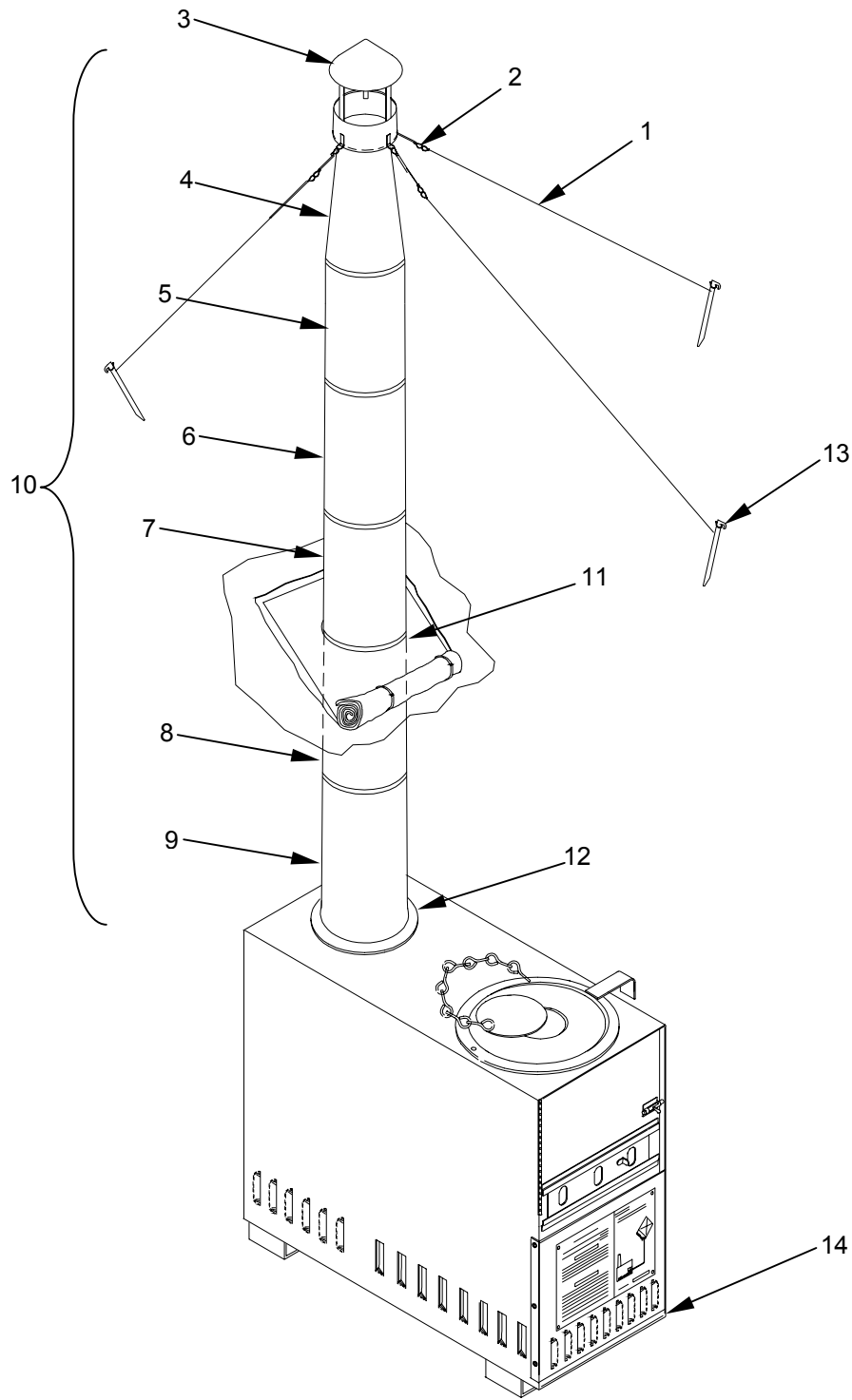

OPERATION IN LIQUID FUEL MODE

Includes the preparation, operation, shutdown, and disassembly instructions for the SHA when operating with liquid fuel.

PREPARING THE SHA FOR LIQUID FUEL OPERATION



WARNING!

Fire or Explosion

If fuel flow control valve assembly is improperly positioned or if bracket is bent, a fuel overflow could occur inside burner shell and cause a fire or explosion.

Slide fuel flow control valve bracket **(1)** from front to back fully into the sleeve **(2)** on the right side of the heater. Be certain that the control valve **(3)** is fully seated in the sleeve, does not bind in the sleeve, and is level with heater **(4)** when installed.

Reach into the cutout area **(5)** on the right side of the SHA and pull out the control valve fuel discharge hose **(6)**.

Connect control valve fuel discharge hose QD connector **(7)** to fuel discharge fitting **(8)** on base of control valve **(3)**.

Connect fuel overflow hose **(9)** to fuel overflow fitting **(10)**.

Connect fuel supply hose **(11)** to fuel inlet fitting **(12)**.



WARNING!

Fire or Explosion

Heat or sparks from stack assembly could ignite fuel supply. Set up fuel supply on a clear site seven feet (2.13 meters) or more from shelter and away from open flame sources.

PREPARING A FUEL SUPPLY SITE

Select a level fuel supply site, free of debris and open flame, at least seven feet (2.13 meters) from shelter.



NOTE!

Open end of overflow hose should discharge to a safe, outside location along a downslope and below the level of the fuel flow control valve. A piece of commercial petroleum absorbent material, such as New Pig's Stat-Mat roll, will be placed under the end of the overflow hose to catch any fuel that may spill. Additional commercial products are available to contain large spills, such as New Pig's Absorbent Sock.

Route the overflow hose (13), and fuel supply hose (14), outside the shelter to the fuel supply location. The overflow hose (13) should discharge to a safe, downward sloping, outside location below the level of the fuel flow control valve. Place a petroleum absorbent mat under the open end of the hose.

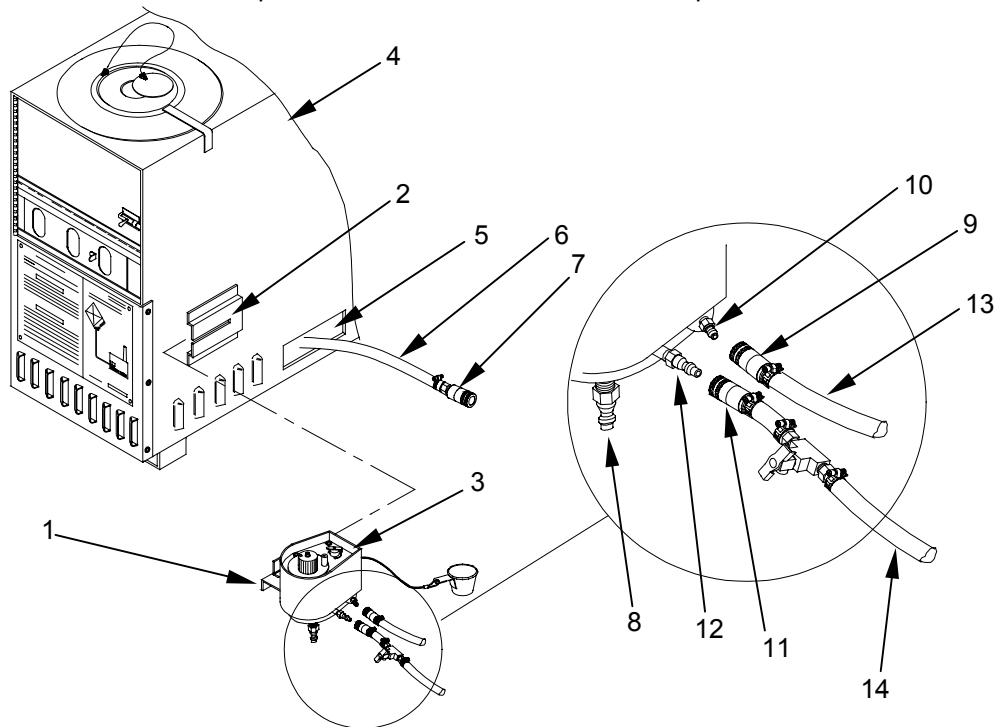



WARNING!
Fire or Explosion

Do not use any fuel not authorized in this manual! Use of unauthorized fuel may result in fire/explosion!

INSTALL GRAVITY FEED ADAPTOR IN FUEL CAN

At the fuel supply site, install a gravity feed adaptor on a full fuel can (filled with fuel as specified in WP 0002) as follows:



WARNING!
Fire or Explosion

Gravity feed adaptor kit must be fully seated to prevent fuel leakage and fire.

Set fuel ON/OFF control (1) on the fuel flow control valve (2) to the OFF position.

Remove cap (3) from mouth (4) of fuel can (5), and replace with gravity feeder adaptor (6). Screw the adaptor into the fuel can securely.

Attach male end (7) of fuel supply hose (8) to gravity feed adaptor fitting (9). Set the assembled fuel can aside.

At the fuel supply site, set up fuel can stand (optional item, refer to AAL WP0045) with fuel can (5) level or slightly above heater as detailed in the next section.

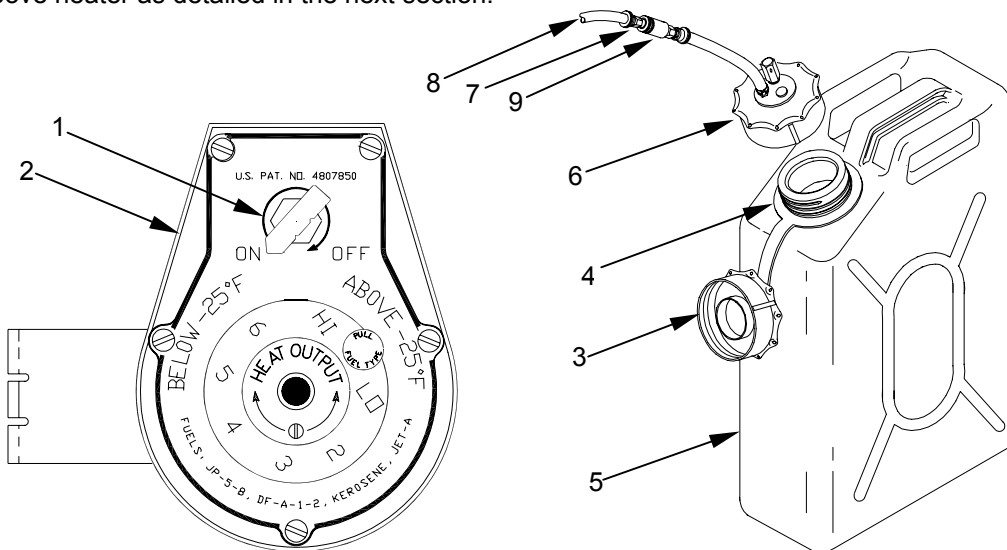

**NOTE!**

If fuel can stand (optional item; refer to WP0045) is unavailable, invert fuel can with installed gravity feed adaptor on a stable support so that the bottom of the fuel can is two feet (61 centimeters) to three feet (91.5 centimeters) above fuel flow control valve.

Setting up the Fuel Can Stand (optional item; refer to AAL, WP 0045). If liquid fuel is to be used, the fuel can stand (optional item; the fuel can stand is available as an Additional Authorized Item as detailed in WP 0045) must be assembled in order to mount the fuel can in the proper position. The fuel can, outfitted with a fuel can gravity feed adaptor, must be mounted to the stand with the gravity feed adaptor facing down.

Insert the bottom leg assembly **(1)** into the top leg assembly **(2)** until each leg is locked in place. Be sure to orient each bottom leg so that the stabilizing straps **(3)** are positioned toward the inside of the stand. Ensure that the straps are not twisted.

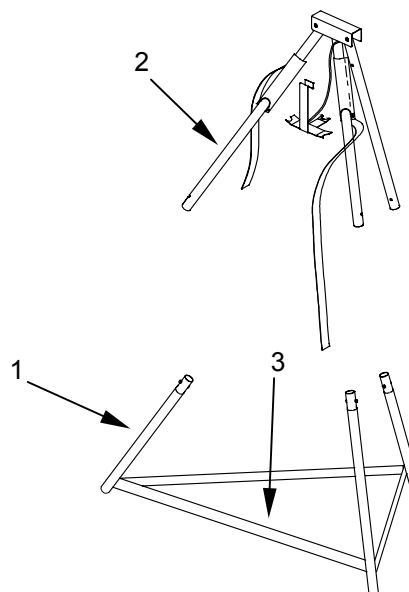

Spread the assembled leg assembly **(4)** until the stabilizing straps **(3)** are fully extended and the stand is stable.

The leg assembly straps are designed to ensure the stand is stable, but are also designed to prevent the stand from sinking into snow.

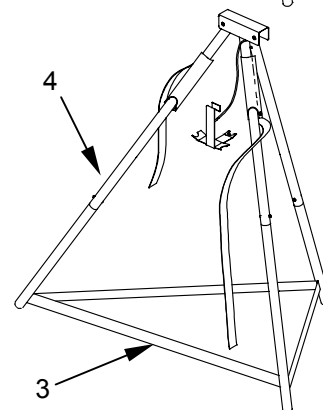

**SPACE HEATER ARCTIC (SHA)
OPERATION UNDER USUAL CONDITIONS**

0005 00

Lower the left (5) and right (6) support arms so that each is at a right angle to its attached leg. Place the tripod brace (7) under the top bracket (8) of the stand and clip into position over the front of the top bracket.

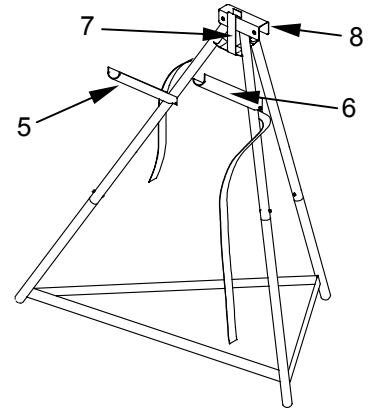
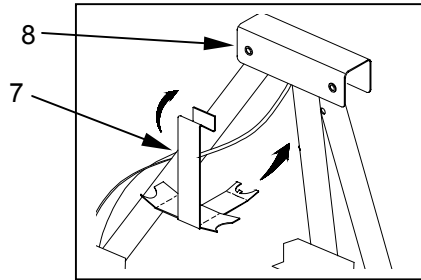

NOTE!

Make sure that the Fuel Can Gravity Feed Adapter is fully seated and secured to avoid leaking.

Invert the fuel can with installed gravity feed adaptor (9) and mount on the assembled fuel can stand so that the gravity feed (10) adapter faces the ground. Slide the right support arm (8) through the handle (11) of the fuel can. Wrap the left support strap (12) over the bottom of the fuel can (9). Feed the right support strap (13) through the fuel can handle (11), up across the front of the fuel can body, and over the left support strap (12). Secure the right strap (13) to the left strap. The strap helps secure a partially filled fuel can to the fuel stand during windy conditions.

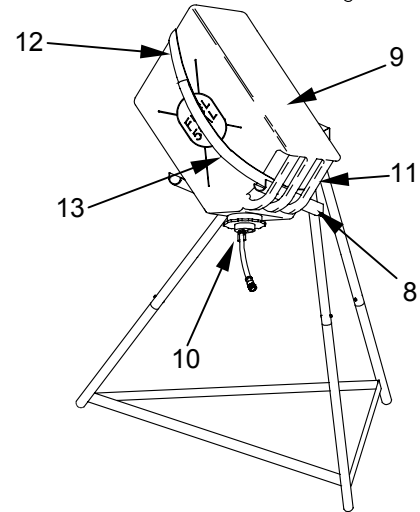

STARTING THE HEATER IN LIQUID FUEL MODE**WARNING!****Fire or Explosion**

Never attempt to light a heater that may still be hot. Allow the heater to cool sufficiently before lighting. Lighting a heater that is still hot may result in fire/explosion!

SETTING THE FUEL FLOW CONTROL VALVE

Lift fuel selector control knob **(2)** on the Fuel Flow Control Valve **(1)** and set in accordance with the outside temperature. There are two positions, ABOVE -25°F and BELOW -25°F . Pull the knob and rotate it to the desired position. Release the control knob, making sure that the knob locks in the detent for the desired position.

Set fuel ON/OFF control **(3)** to ON.

Set flow adjustment knob **(4)** to HI; wait 2 to 5 minutes in order to allow the fuel flow control valve **(1)** and burner up-tube **(5)** to fill with fuel.

Shake or tap hoses **(6)** to clear any air bubbles that may be trapped in the hoses.

Open the door assembly **(7)** and verify that the Burner Cover Assembly **(8)** has been installed in the door frame **(9)**. Shut and latch the door **(7)**.

PRIMING THE BURNER

Open the heater lid **(11)**.

Be sure that the down-tube **(12)** is securely fitted over the up-tube **(5)** inside the burner **(10)**.

Hold the priming cup **(13)** under priming valve **(14)** on fuel supply hose. Open the valve **(14)** slowly and fill the cup **(13)** with fuel. Shut valve **(14)** when cup is full.

Pour fuel into the bottom of burner **(10)**. If the outside temperature is below -25°F (-32°C), pour an additional cup of fuel into the bottom of the burner.

Take a short length of toilet tissue (or paper) and roll the paper into a ball. Soak up any excess fuel that may remain in the cup **(13)**; do not discard the paper.

Light the fuel soaked toilet tissue and toss it into the bottom of the burner **(10)**.

Use the cleaning tool **(15)**, if necessary, to make sure that the burning tissue reaches the bottom of the burner **(10)** where it can ignite the priming fuel. Make sure that the burning tissue remains down in the burner. Close the Lid Assembly **(11)**.

When the heater has warmed up sufficiently and begins to give off heat (approximately 5-10 minutes), gradually adjust the flow adjustment knob **(4)** to desired heat output.



NOTE!

In extremely cold conditions, if the firing rate on HI setting is not generating sufficient heat output, tap the control valve and shake the hoses to eliminate any air that may be trapped. If output is still insufficient, turn the heater control valve to LO for 5-10 minutes, which will heat the bottom of the burner. Then turn the control valve back to the HI position.

Be sure to perform "DURING Operation" Preventive Maintenance Checks and Services (PMCS) as detailed in WP 0010 while the heater is in operation.

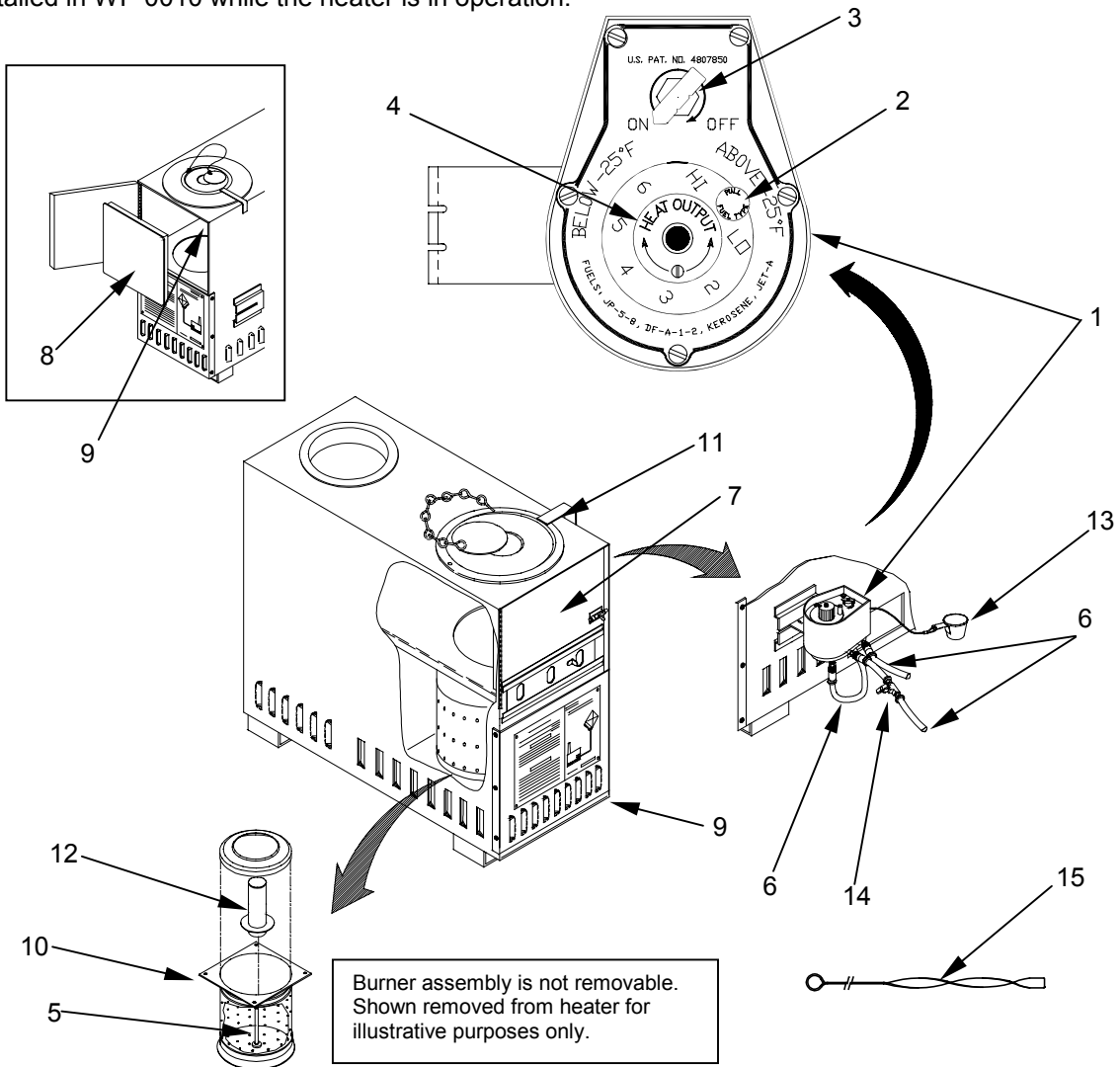

OPERATING THE THERMOELECTRIC FAN (TEF)
(optional item, refer To AAL, WP 0045)**WARNING!**
Hot Surfaces

The base plate of the TEF gets very hot during operation. Take care in handling the fan to avoid burns or other serious injury.

**CAUTION!**

Do not block the flow of air out of the fan by placing gloves or other articles on the grill of the fan.

The base plate of the TEF gets very hot during operation. If it is necessary to remove the TEF from the Lid Assembly while the heater is in operation, be sure to place the TEF on a surface that will not melt or burn.

The Thermoelectric Fan (TEF) **(1)** helps to circulate the heat generated by the space heater **(2)** to the floor and throughout the shelter. The TEF is self powered and generates its own power directly from the heat radiated by the space heater. As the TEF base plate heats up, that heat is converted into electrical energy to operate the fan. The TEF is an optional piece of equipment and is listed in the Additional Authorization Items list (WP 0045).

To unpack the TEF from its storage container **(3)**, release the latches **(4)** that secure the cover **(5)** and remove. Grasp the TEF by the handle **(6)** mounted on the grill and lift out of the container **(3)**.

To operate the TEF, remove the sight glass cover **(7)** from the top of the lid assembly **(8)** and allow it to hang over the left side of the heater. Place the TEF **(1)** in position on the lid assembly **(8)** of the SHA. Within 5-10 minutes, the fan will reach full operating capacity.

To repack the Thermoelectric Fan **(1)**, allow it to cool completely, pick it up by its top handle **(6)** and lower it into the TEF storage container **(3)**. Place the cover **(5)** in position on the top of the storage container. Engage and secure the cover side latches **(4)**.

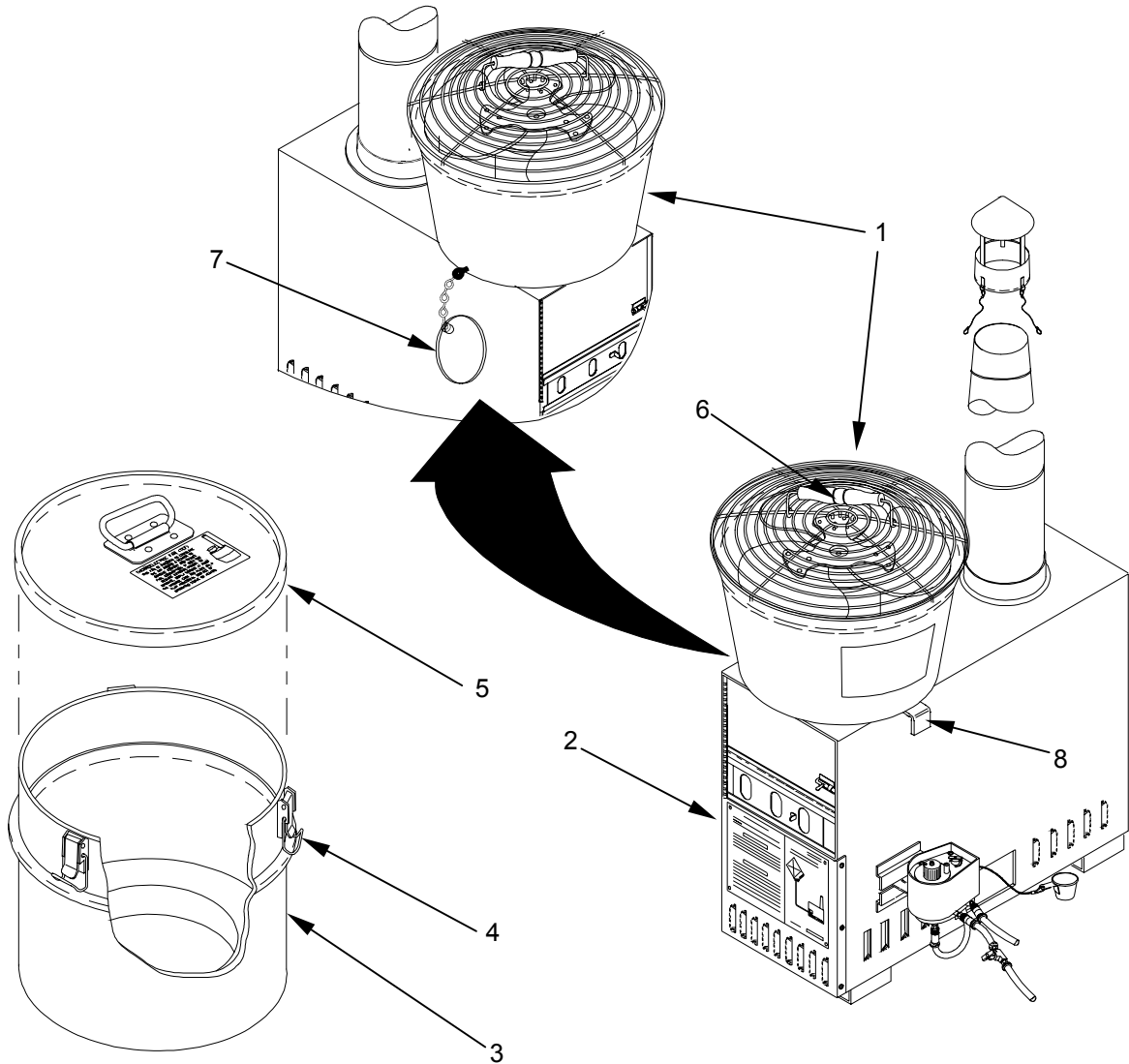

REFUELING



WARNING!

Fire or Explosion

Do not attempt to refuel a hot space heater. Allow the SHA to cool completely before handling or refueling.

Set fuel ON/OFF control (1) to OFF to shut down heater.

Remove fuel can from fuel can stand and replace with a full fuel can as detailed earlier in this work package.

Restart heater.

SHUTDOWN FROM LIQUID FUEL OPERATION

Set fuel ON/OFF control (1) to OFF.

Remove fuel can from fuel can stand.

Allow equipment to cool down. Perform "AFTER OPERATION" PMCS as detailed in WP 0010.

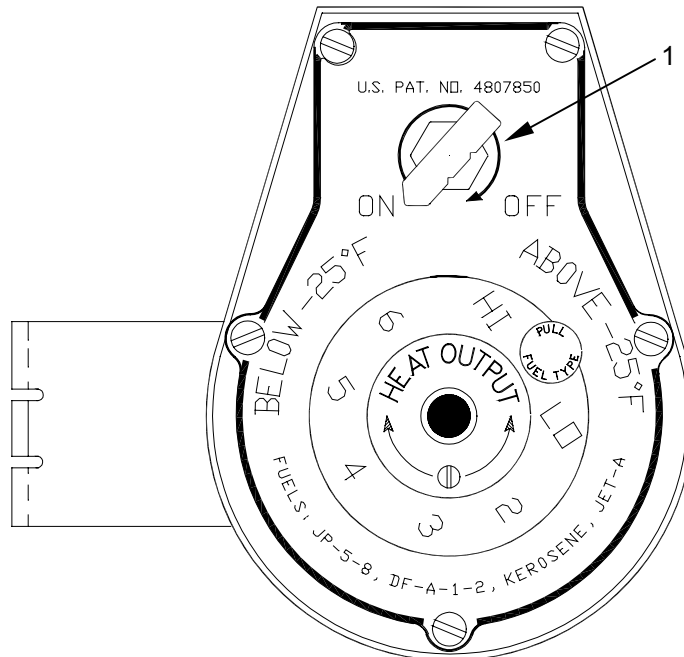

PREPARATION FOR MOVEMENT AFTER LIQUID FUEL OPERATION**DISASSEMBLING THE STACK ASSEMBLY****WARNING!**
Hot Surfaces

Do not disassemble a hot heater. Allow the heater to cool completely before handling or moving. Handling a hot heater may result in severe burns.

On the outside of the shelter, untie the stack cap assembly guy lines (1) from their ground stakes (2). Remove ground stakes (2) and stow.

On the inside of the shelter, lift the exhaust stack assembly (3) with stack cap assembly (4) and attached lines (1) from stack adaptor opening (5). Lower the stack assembly through the exhaust opening (6), and set on piece of wood to prevent gouging of shelter floor. Remove the lower sections of the stack assembly (3) and lower the remainder of the stack assembly until the stack cap (4) with attached lines (1) is positioned near the exhaust opening closure (6). On the outside of the shelter, have a second person remove the stack cap assembly (4) with attached guy lines (1) from the top section of the stack assembly. Lower the remainder of the stack assembly through the exhaust opening closure (6). Close and secure the exhaust opening closure (6).

Disassemble and nest the stack assembly (7). Set stack cap (4) with attached guy lines (1) aside.

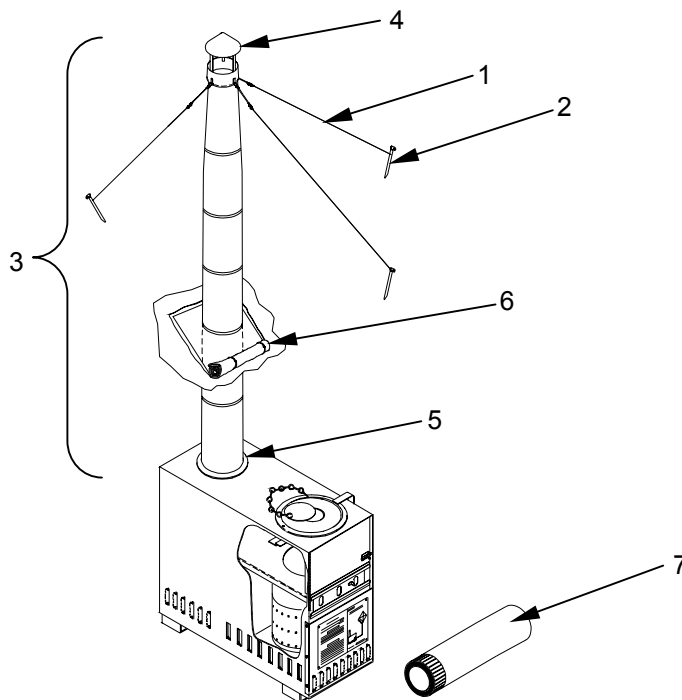

STRIKING THE FUEL SUPPLY SITE

Unstrap and remove the fuel can (1) from fuel can stand (2); position the fuel can upright on ground.

Disconnect the fuel supply hose (3) and fuel overflow hose (4) from the fuel flow control valve (5). Coil fuel supply hose (3) and fuel overflow hose (4) from the heater (6) to the fuel supply site. Drain any excess fuel back into the fuel can (1) by opening the priming valve (7) on the fuel supply hose (3) to allow air to enter the hose (3). Be sure to close the valve (7) when done.

Disconnect fuel supply hose (3) from gravity feed adaptor (8). Connect the two connectors on the ends of the fuel supply hose (5) together in order to keep the connectors free of any debris.

Unscrew and remove the adaptor (8) from fuel can (1) and install the fuel can cap (9). Set gravity feed adaptor (8) aside for repacking in SHA.

Disassemble fuel can stand (2) as described earlier in this work package. Stow fuel can (1) and stand (2) in authorized location.

In the event that fuel is spilled on the ground, immediate action must be taken to contain the spill and the appropriate environmental personnel notified. Clean up any spilled fuel with a rag. Dispose of rag and/or absorbent material in accordance with local Material Safety Data Sheet (MSDS) procedure.

Disconnect valve discharge fuel hose (10) from valve (5). Slide valve (5) toward front of heater (6) and remove valve (5) from sleeve (11). Before packing, drain any fuel remaining in the valve (5) into the fuel can (1) by aligning the hole (12) on the rear side of the valve (5) over the open fuel can (1). Set valve (5) aside for repacking. Insert the end of the valve discharge fuel hose (10) into the rectangular cutout (13) on the side of the heater (6) and store the remaining hose (10) inside the heater compartment (14).

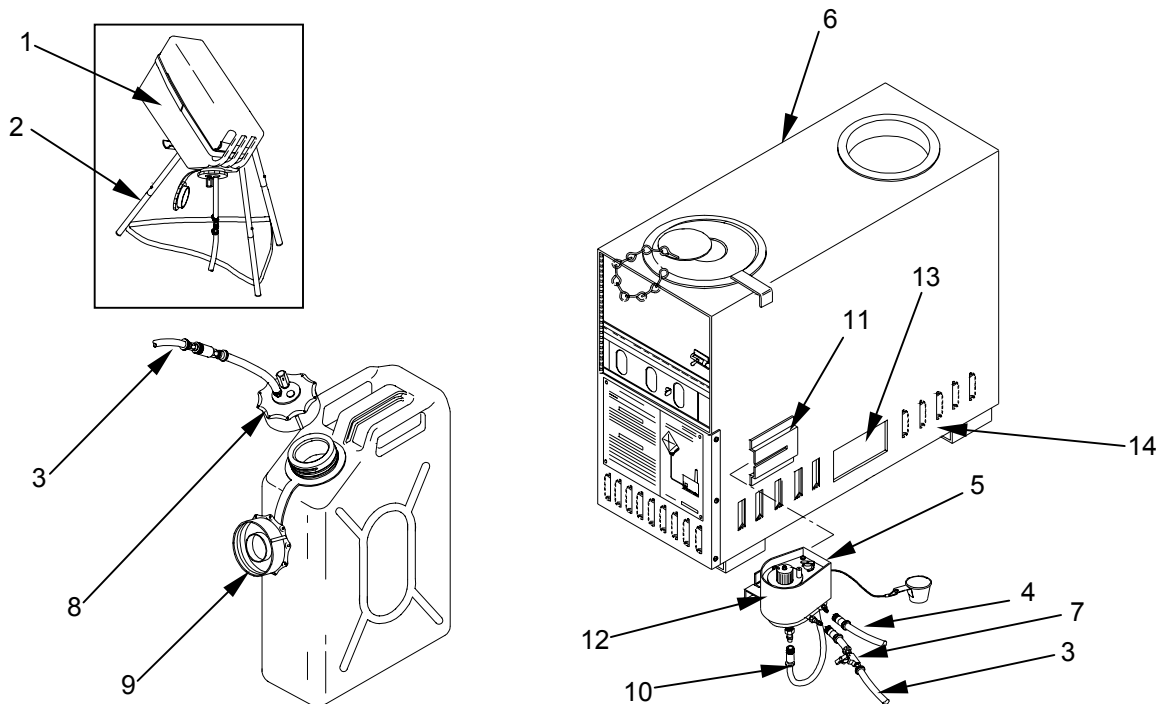

REPACKING SHA COMPONENTS



WARNING!
Two Person Lift

The SHA weighs approximately 40 pounds (18 kg). Two persons must carry the SHA when lifting or lowering the unit from 3 feet or more. Be sure to lift with legs, not back, to prevent injury.

To repack the SHA components, unlatch and open the front door (1). Remove the burner cover assembly from the door frame.

Install solid fuel grate (2), with its mounting feet pointing upward.

Stow the nested stack assembly (3) on the right side of the enclosure, on top of the solid fuel grate.

Coil up the fuel overflow hose (4) and place inside the nested stack assembly (3).

Stow the lid assembly (5) against the left side wall of the heater. Coil up and store the fuel supply hose (6) between the lid assembly (5) and the nested stack assembly (3). Be sure that the metal hose connections do not hit or rest against the sight glass of the lid assembly (5) or breakage of the glass may occur.

Store the cleaning tool (7) on top of solid fuel grate (2). Replace the burner cover assembly in the door frame. Shut and latch door (1).

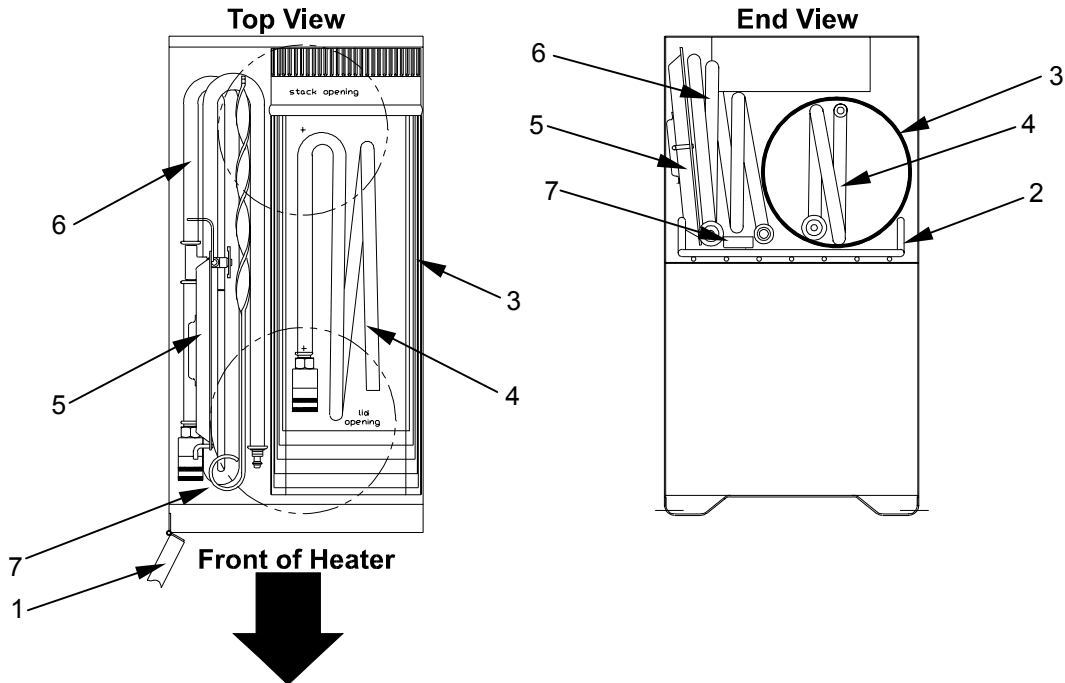

**SPACE HEATER ARCTIC (SHA)
OPERATION UNDER USUAL CONDITIONS**

Press down on the top edge of the rear door, swing out and remove.

Wrap tent lines around the stack cap (1) (or stuff the lines inside the cap) and place on the upper right side of the rear storage enclosure (2)

Place the Fuel Flow Control Valve (3) in the lower left side of the rear storage enclosure (2).

Place the Gravity Feed Adaptor (4) in front of the Fuel Flow Control Valve (1).

Install the rear door over the storage compartment by placing the bottom edge of the door in the slot along the lower edge of the rear storage compartment and, while applying downward pressure, press the rear door into the rear storage compartment door frame until it clears the retaining pin. Release the rear door.

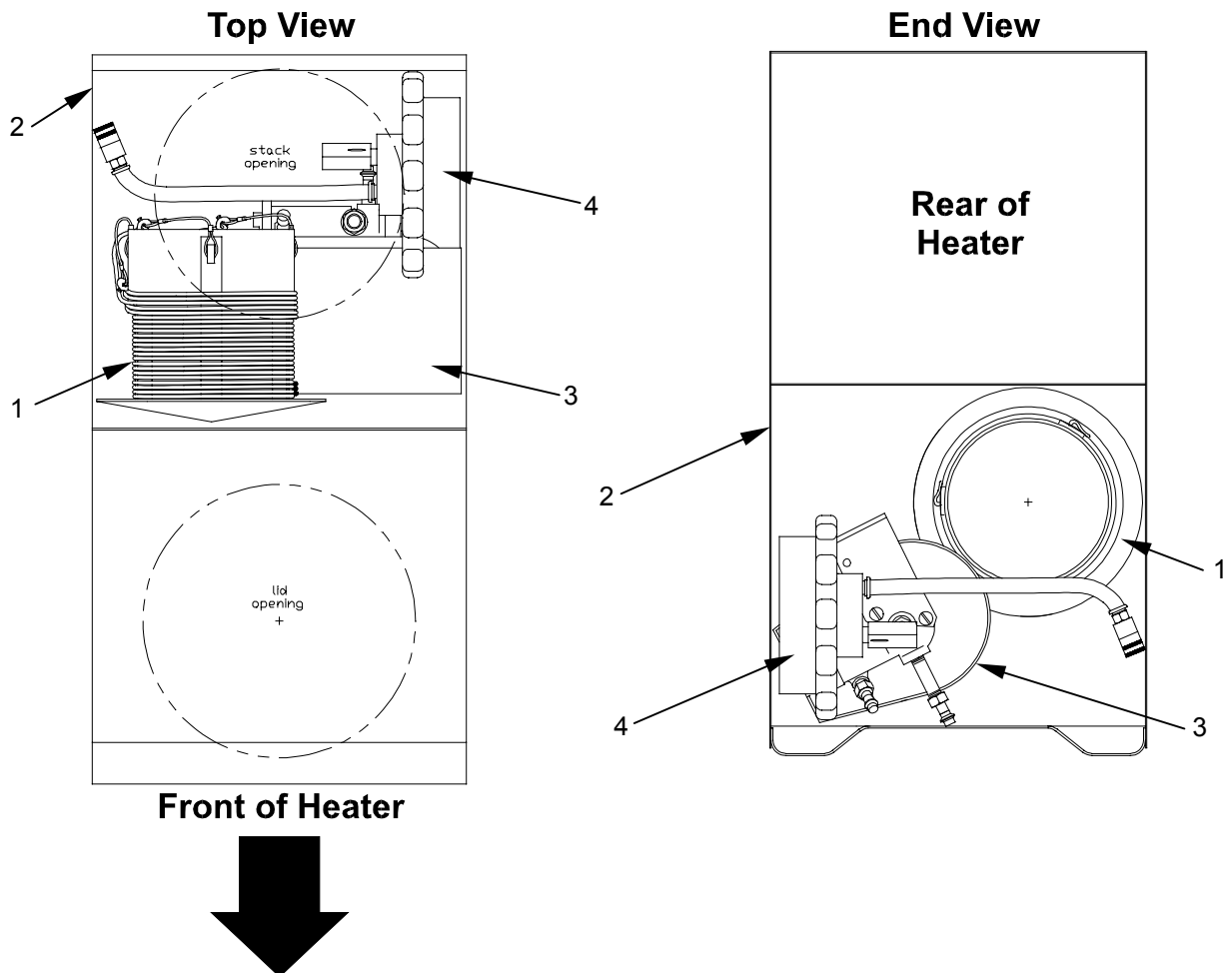

OPERATING THE SHA IN SOLID FUEL MODE

Includes the setup, operation, shutdown, and disassembly of the SHA when operating in solid fuel mode as follows:



CAUTION!

Do Not Leave Any Components Inside Heater Frame

All components stored in the storage compartment of the heater must be removed prior to solid fuel operation. Components are stored in both the upper and lower portions of the heater. Most of these items are liquid fuel components which could be damaged by high heat when the heater is operated with solid fuel.

PREPARATION FOR SOLID FUEL OPERATION

Ensure that all components have been unpacked as discussed earlier in this work package. Ensure that the heater is positioned properly in the shelter and that the stack assembly has been installed as described in the section entitled "Assembling the Stack Assembly" found earlier in this work package.

Open front door **(1)** and verify that the burner cover assembly **(2)** is installed over the burner. If the burner cover assembly **(2)** is installed in the door frame, remove it from the door frame, lift the solid fuel grate **(3)** and put the burner cover in position over the burner **(4)** as described earlier in this work package in the section entitled "Installing the Burner Cover Assembly and Solid Fuel Grate".

Make certain that the solid fuel grate **(3)** is in position on its feet.

PREHEATING THE FLUE

To help ensure that no smoke blows back into the shelter on heater startup, the flue should be preheated by opening the door **(1)** and placing 2 or 3 crumpled pieces of paper on the solid fuel grate **(3)**. Ignite the paper with a match, close and latch the front door **(1)** and open the draft gate **(5)**. When the paper has burned completely, add solid fuel and start the heater as described below.

ADDING SOLID FUEL AND STARTING THE HEATER



WARNING! Fire or Explosion

Do not use any type of accelerant (i.e. gas, kerosene, jet fuel etc.) to help ignite solid fuel. Explosion or uncontrolled fire may result.

**WARNING!**
Stack Fire

When operating the heater in solid fuel mode, a buildup of creosote can accumulate on the inside surface of the stack assembly that may result in a fire inside the stack. To prevent creosote buildup when operating with solid fuel, the stack assembly should be cleaned daily. Failure to do so may result in a fire causing severe injury or death.

**CAUTION!**
Warping of Heater

Heater components may warp from excessive heat caused by an over fueled fire. Wood and coal can burn extremely hot depending on the type and size of fuel used. Do not overfuel fire and clean ashes frequently. If coal is being used as a fuel, add only a small amount of coal at a time. Coal is very dense and provides high heat output. Overfilling the heater with coal will cause the heater to run extremely hot and it will be very difficult to control the heater's temperature output.

**WARNING!**
Hot Surfaces

Door and lid assemblies are very hot during operation. Use the cleaning tool to open the lid or unlatch/open the front door. Handling door or lid assemblies during operation may result in severe burns.

After preheating the flue as described above, open the front door **(1)** and position enough crumpled paper on solid fuel grate **(3)** to cover it. If using wood as a solid fuel, stack four to five pieces wood approximately $\frac{1}{4}$ to $\frac{1}{2}$ inches in diameter (kindling) in a crisscross fashion on top of paper. If using coal as a solid fuel, place 10-12 pieces of coal that are approximately 2 inches in diameter on top of the paper.

Light the paper with a match. When kindling begins to burn steadily, place 2-3 larger pieces of wood or a small amount of additional coal on top of kindling. Fuel may be fed either through lid **(4)** or front door assembly **(1)**.

Shut/latch door **(1)**. Keep door **(1)** and lid **(4)** assemblies shut except when fueling fire or removing ashes.

Adjust sliding draft gate **(5)** (open more to increase burn rate and close more to decrease burn rate). Monitor flame through the sight glass **(6)** on the lid.

Remove ashes frequently with a small pack shovel or scoop (not included with SHA) so that the ashes do not accumulate up above the solid fuel grate (3).

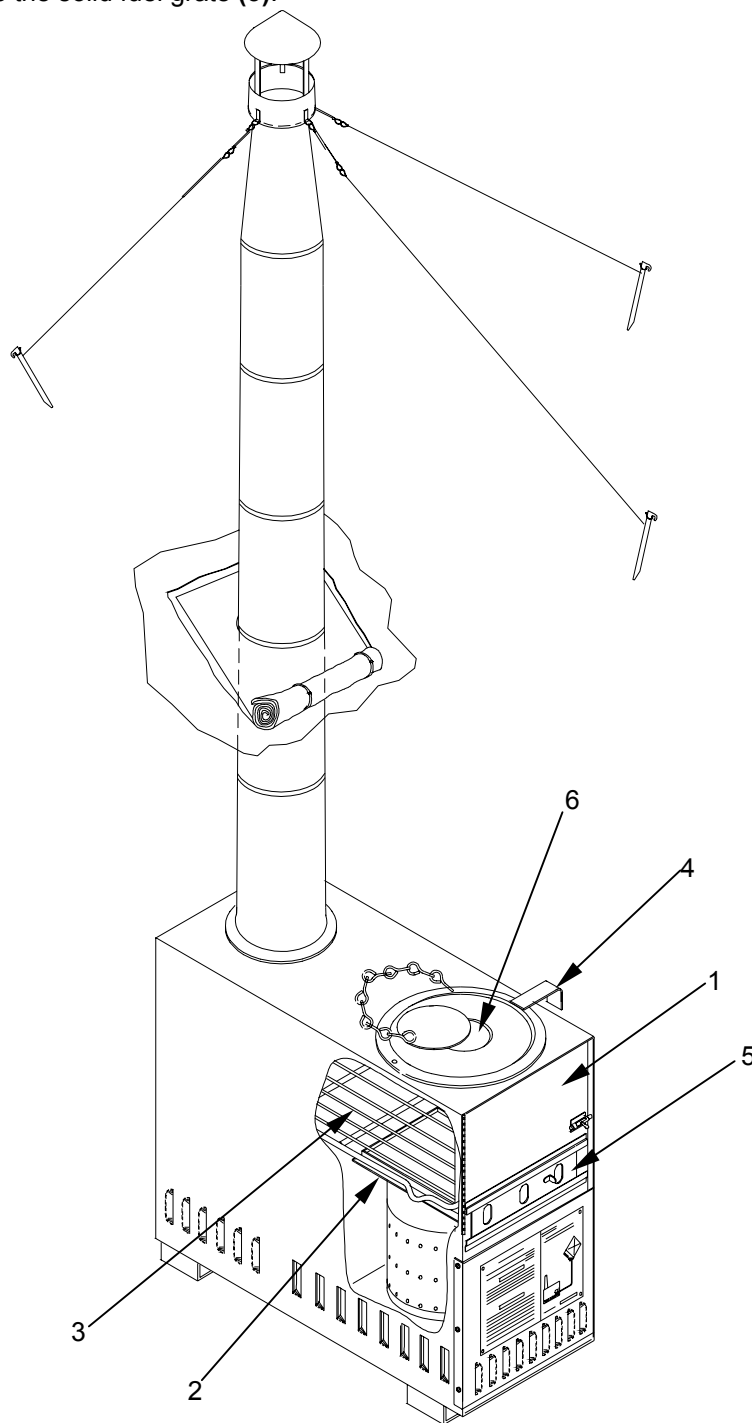

ADDING ADDITIONAL SOLID FUEL**WARNING!**
Hot Surfaces

The SHA becomes extremely hot while operating. Touching operating equipment without protective clothing when adding fuel may cause severe burns.

Add fuel as needed to maintain fire as follows.

Open door **(1)**. Using a piece of wood or the cleaning tool **(2)**, push the live burning fuel back into heater and position new fuel in front. Allow the new fuel to ignite before adding more. Add fuel until desired burn rate is reached, but do not overfuel. It will take 5 or 10 minutes for the heater to operate at maximum after adding additional fuel. It may take some time to become familiar with the heater's burner rate as different types of wood and coal have varying moisture levels.

After adding fuel, shut and latch door **(1)**. Keep lid **(3)** and door **(1)** assemblies shut except when fueling fire or removing ashes.

SHUTDOWN FROM SOLID FUEL OPERATION

Shut sliding draft gate **(4)** on door **(1)** until fire is extinguished.

**WARNING!**
Burn and Fire Hazard

If ashes are still live when being removed, be sure to wear safety clothing/gloves to prevent burns. Dispose of coals safely so that they don't pose a fire hazard. Use caution when disposing of ashes. Clear an area to bare subsoil and empty the ashes. Drench the area with water, stir the ashes, and drench with water again. Cover the area with dirt.

Allow the equipment to cool down. Perform "AFTER OPERATION" PMCS as detailed in WP 0010.

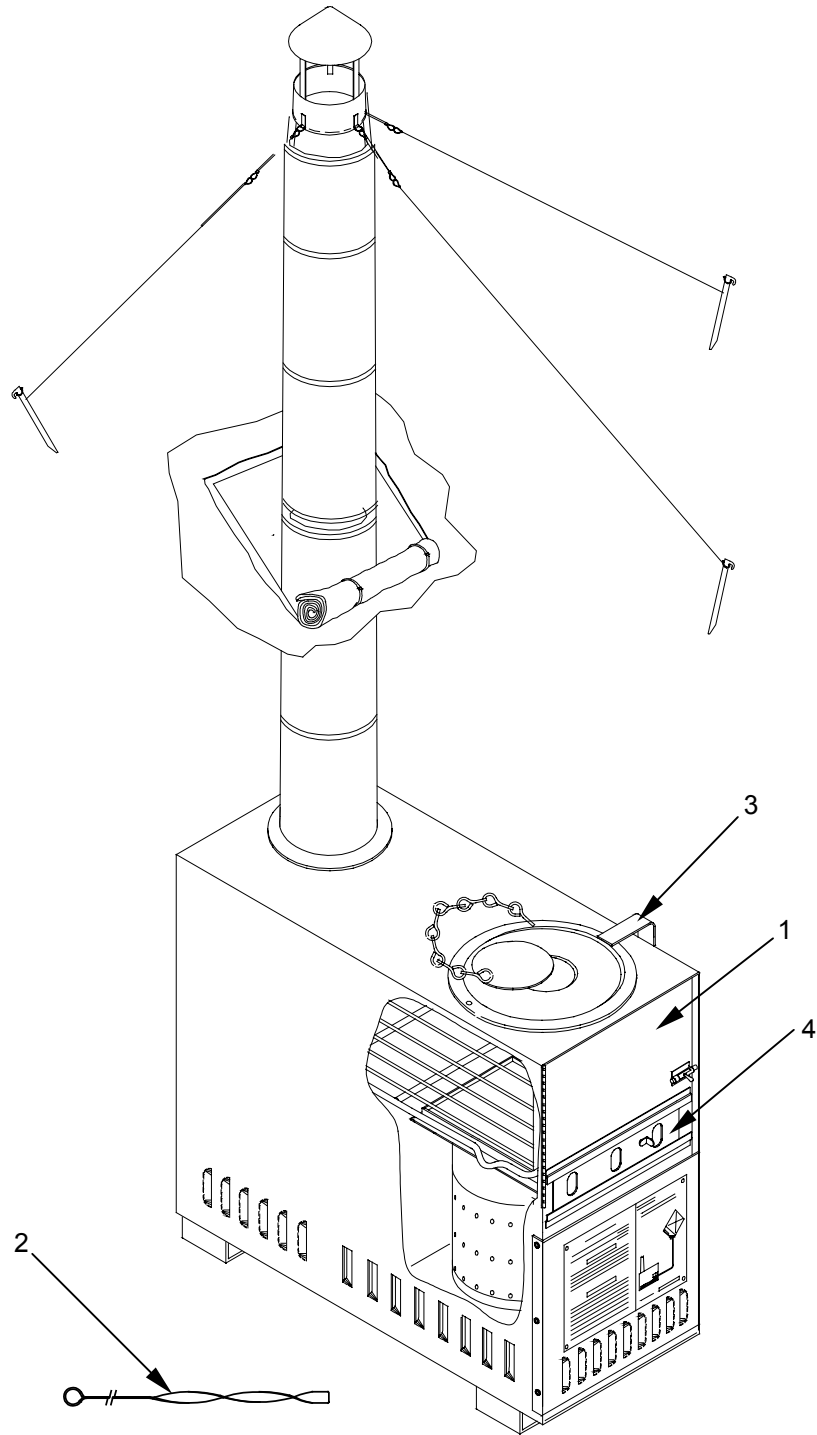

PREPARATION FOR MOVEMENT AFTER SOLID FUEL OPERATION

REMOVE ASHES AND UNBURNED FUEL

After operating the SHA in Solid Fuel mode, any ashes and/or unburned fuel must be removed from the heater. To remove ashes from the interior of the heater, slide the latch (1) to the left and open the front door (2).

Remove the solid fuel grate (3) and empty any ashes and unburned fuel into an approved container with a small pack shovel or scoop (not included with SHA). Clean all ashes that have accumulated on the burner cover assembly (4) or upper deck; empty into the container. Dispose of all ashes in an approved manner.

DISASSEMBLING THE STACK ASSEMBLY



WARNING! **Hot Surfaces**

Do not disassemble a hot heater. Allow the heater to cool completely before handling or moving. Handling a hot heater may result in severe burns.

Untie shelter lines (5) from ground stakes (6). Remove ground stakes (6) and stow.

Lift exhaust stack (7) with stack cap assembly (8) and attached lines (5) from stack adaptor opening (9). Pull through shelter exhaust opening (10), and set on piece of wood to prevent gouging of shelter floor. Pull in shelter lines (1) and close the exhaust opening closure (6).

Disassemble and nest the stack assembly (11). Set stack cap (8) with attached shelter lines (5) aside for repacking.

REPACKING THE SHA AFTER SOLID FUEL OPERATION



WARNING! **Two Person Lift**

The SHA weighs approximately 40 pounds (18 kg). Two persons must carry the SHA when lifting or lowering the unit from 3 feet or more. Be sure to lift with legs, not back, to prevent injury.

Repack the SHA components as detailed earlier in this work package in the section entitled "Repacking SHA Components".

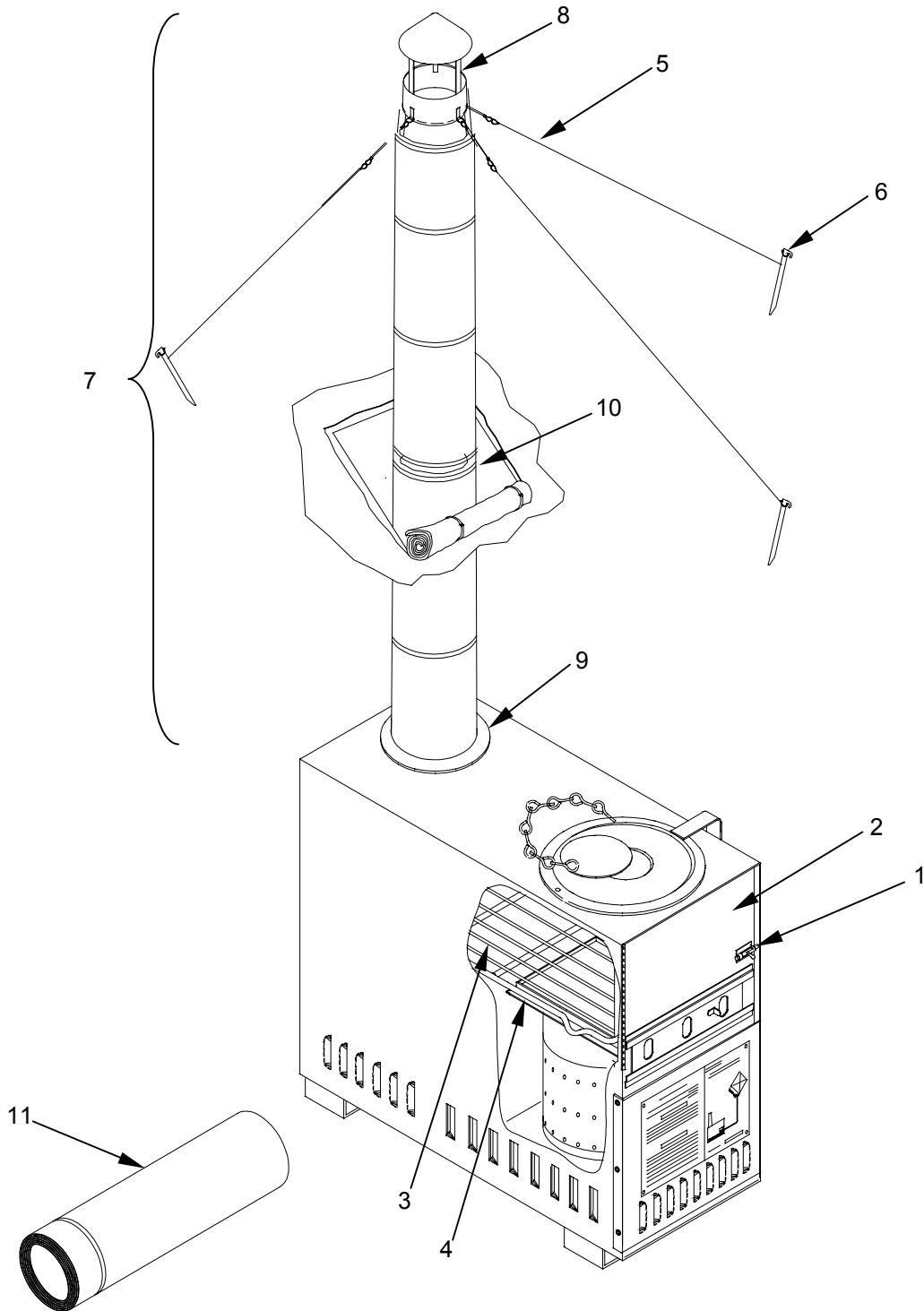

PREPARATION FOR STORAGE AND SHIPMENT**GENERAL****WARNING!**
Two Person Lift

The SHA weighs approximately 40 pounds (18 kg). Two persons must carry the SHA when lifting or lowering the unit from 3 feet or more. Be sure to lift with legs, not back, to prevent injury.

Heater must be shut down and disassembled as described in this work package. Follow the appropriate instructions depending on the fuel type being used.

Perform all AFTER OPERATION Preventive Maintenance Checks and Services (PMCS) as described in WP 0010.

If any maintenance is required at the unit level, refer to the heater to unit maintenance for repair prior to storage or shipment.

OPERATION IN UNUSUAL ENVIRONMENT/WEATHER CONDITIONS

GENERAL

Refer to Operation Under Usual Conditions (WP 0005), for specific operating instructions, and use this work package for further instruction if operating the heater in unusual conditions. Read all sections which apply to the conditions to which your heater will be exposed.

Sections are broken down into general solid and liquid fuel operation conditions and specific solid or liquid fuel operation conditions.



WARNING! **Carbon Monoxide**

During operation, the SHA produces harmful carbon monoxide (CO) and other gases. Carbon monoxide is a colorless, odorless, and tasteless gas. Mild cases of carbon monoxide poisoning can cause symptoms such as nausea, dizziness or headaches. Severe cases of carbon monoxide poisoning can result in brain damage, heart damage or death. Remember that although CO has no telltale odor, it may mix with other odors which mask its presence; therefore, CO can be present within a mix of seemingly harmless odors.

To prevent CO poisoning, ensure that the SHA exhaust stack sections fit together snugly and that the exhaust gases are properly vented through the roof of the shelter.

The best way to prevent CO poisoning is to keep the SHA in good working order. Ensure that all possible sources of CO leakage have been repaired and that the operating space is well ventilated.

OPERATION IN DUSTY OR SANDY CONDITIONS

Solid and liquid fuel operation. Care should be exercised when using the SHA in sandy or dusty conditions to ensure that all connectors and fittings remain free of sand. To prevent sand from contaminating the connectors and fittings, leave the hoses in either the stored or operating configuration at all times.

Solid fuel operation only. None.

Liquid fuel operation only. Before making connections, inspect fuel line ends and fuel flow control fittings for dust or sand fouling.

Keep lids installed tightly on all fuel containers.

OPERATION IN COLD CONDITIONS**WARNING!
Freeze Hazard**

Severe injury may occur to personnel handling metal parts without protective gloves when temperatures are below freezing. Skin may freeze upon contact and tear from the flesh.

Do not allow fuel to come in contact with bare skin. Even though fuel does not freeze, it is extremely cold and will burn exposed skin on contact. Wear protective gloves whenever handling or working with liquid fuel.

Solid and liquid fuel operation. Do not handle metal components without protective gloves when temperatures are below freezing (32 degrees Fahrenheit).

Solid fuel operation only. Do not overfuel the heater. This could cause overheating of stack assembly and ignite tent fabric.

Liquid fuel operation only. When temperature is below -25 degrees Fahrenheit (-31 degrees Celsius), use JP-5, JP-8, or DF-A fuel.

OPERATION IN HIGH ALTITUDE CONDITIONS

Solid and liquid fuel operation. Inspect heater operation more frequently.

Solid fuel operation only. Adjust sliding draft gate as required to prevent over firing.

Liquid fuel operation only. Lower than normal operating settings of flow adjustment knob may be desirable to prevent over firing and carbon buildup.

OPERATION IN RAINY OR HUMID CONDITIONS

Solid and liquid fuel operation. If tent is set up on in extremely damp and muddy areas, set heater legs on stones or boards to prevent it from sinking.

Take extra precautions in securing stack cap and telescoping stack assembly with ground stakes (ie: use longer stakes).

If heater has been exposed to rain, drain it of any large water deposits before trying to light it off.

Solid fuel operation only. Store matches, kindling, coal and wood in a dry, sheltered location.

If the only supply of re-fuel available is wet or damp, position a regular amount of the wet/damp fuel next to the operating heater to dry for refueling purposes.

Liquid fuel operation only. Prevent fuel contamination by keeping lids tightly on fuel containers.

OPERATION IN SALT WATER AREAS

Solid and liquid fuel operation. Keep heater free from salt water contact as much as possible.

Wash heater frequently with fresh water if exposed to salt spray, to prevent corrosion.

Solid fuel operation only. None.

Liquid fuel operation only. None.

OPERATION IN SNOWY OR SNOW-COVERED CONDITIONS

Solid and liquid fuel operation. If tent is set up on large accumulations of snow, set heater legs on stones or boards to prevent it from sinking.

Do not allow snow to accumulate in large amounts (over six inches [15.3 centimeters]) on sides of the tent which are next to the operating heater.

Take extra precautions in securing stack cap and telescoping stack assembly with ground stakes (ie: use longer stakes).

If heater has been exposed to the weather, remove any large deposits of snow and ice before operation.

Solid fuel operation only. Store matches, kindling, coal and wood in a dry, sheltered location.

If the only supply of fuel available is wet or damp, position a regular supply of the wet/damp fuel near the operating heater to dry, for refueling purposes.

Liquid fuel operation only. Prevent fuel contamination by keeping lids tightly on fuel containers.

NBC DECONTAMINATION PROCEDURES

Perform interim decontamination procedures in accordance with FM 3-5.

THIS PAGE INTENTIONALLY LEFT BLANK

CHAPTER 3

**OPERATOR TROUBLESHOOTING AND SERVICE PROCEDURES
FOR
SPACE HEATER ARCTIC**

THIS PAGE INTENTIONALLY LEFT BLANK

LUBRICATION REQUIREMENTS

The door hinge and latch assembly should be lubricated with a light machine oil or WD-40 when stored.

SERVICE PARTS OVERPACK

There will not be any service overpack during initial fielding of the SHA.

During the initial fielding period, repair parts may be obtained from the following source:

HUNTER MANUFACTURING COMPANY
30525 Aurora Road
Cleveland, OH 44139

Tel: (440) 248-6111
FAX: (440) 248-1691

Email: huntmfg@ix.netcom.com
Internet: <http://www.hunterheater.com>

THIS PAGE INTENTIONALLY LEFT BLANK

INTRODUCTION TO TROUBLESHOOTING

The Malfunction Index lists common malfunctions that may occur during heater inspection and operation.

Find the malfunction the heater is having in the index and go to the given troubleshooting procedure in the following pages.

These charts cannot list all malfunctions that may occur, all tests or all inspections needed to find the fault, nor all actions required to correct the fault. If your malfunction is not listed in, or is not correctable through, this troubleshooting index, notify Unit Maintenance.

MALFUNCTION SYMPTOM INDEX

Malfunction or Symptom	Refer to Troubleshooting Procedure
LIQUID FUEL MODE	
Heater does not start	1
Heater sputters and misfires	2
SOLID FUEL MODE	
Fire will not start or will not stay lit	3
Excessive smoke while operating	4

THIS PAGE INTENTIONALLY LEFT BLANK

TROUBLESHOOTING PROCEDURES

The troubleshooting procedures contain tables that list possible malfunctions, the tests or inspections to perform, and the corrective action required to return the SHA to normal operation. Perform the steps in the order they appear in the tables.

Each procedure is headed by an initial setup. This setup outlines what is needed as well as certain conditions which must be met before starting the task.

DO NOT START THE TASK UNTIL:

- You understand the task
- You understand what you are to do
- You understand what is needed to do the work
- You have the things you need

This manual cannot list all malfunctions that may occur, or all tests or inspections and corrective actions. If a malfunction is not listed or is not corrected by listed corrective actions, notify unit maintenance.

**SPACE HEATER ARCTIC (SHA)
TROUBLESHOOTING PROCEDURES**

0009 00

THIS PROCEDURE COVERS:
LIQUID FUEL MODE: Heater Does Not Start

Maintenance Level
Operator

Materials/Parts
None

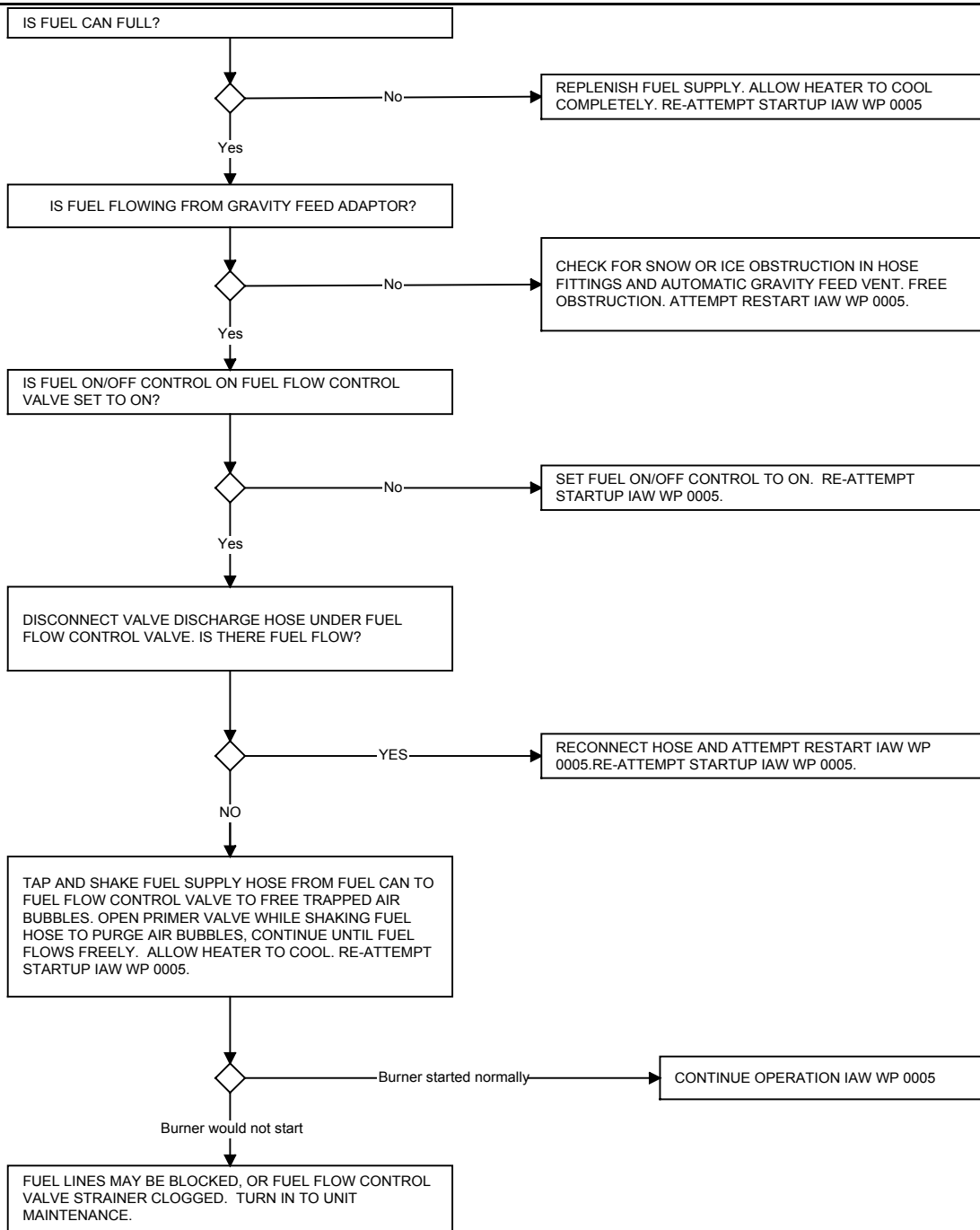

**SPACE HEATER ARCTIC (SHA)
TROUBLESHOOTING PROCEDURES**

0009 00

THIS PROCEDURE COVERS:

LIQUID FUEL MODE: Heater Sputters and Misfires

Maintenance Level

Operator

Materials/Parts

None

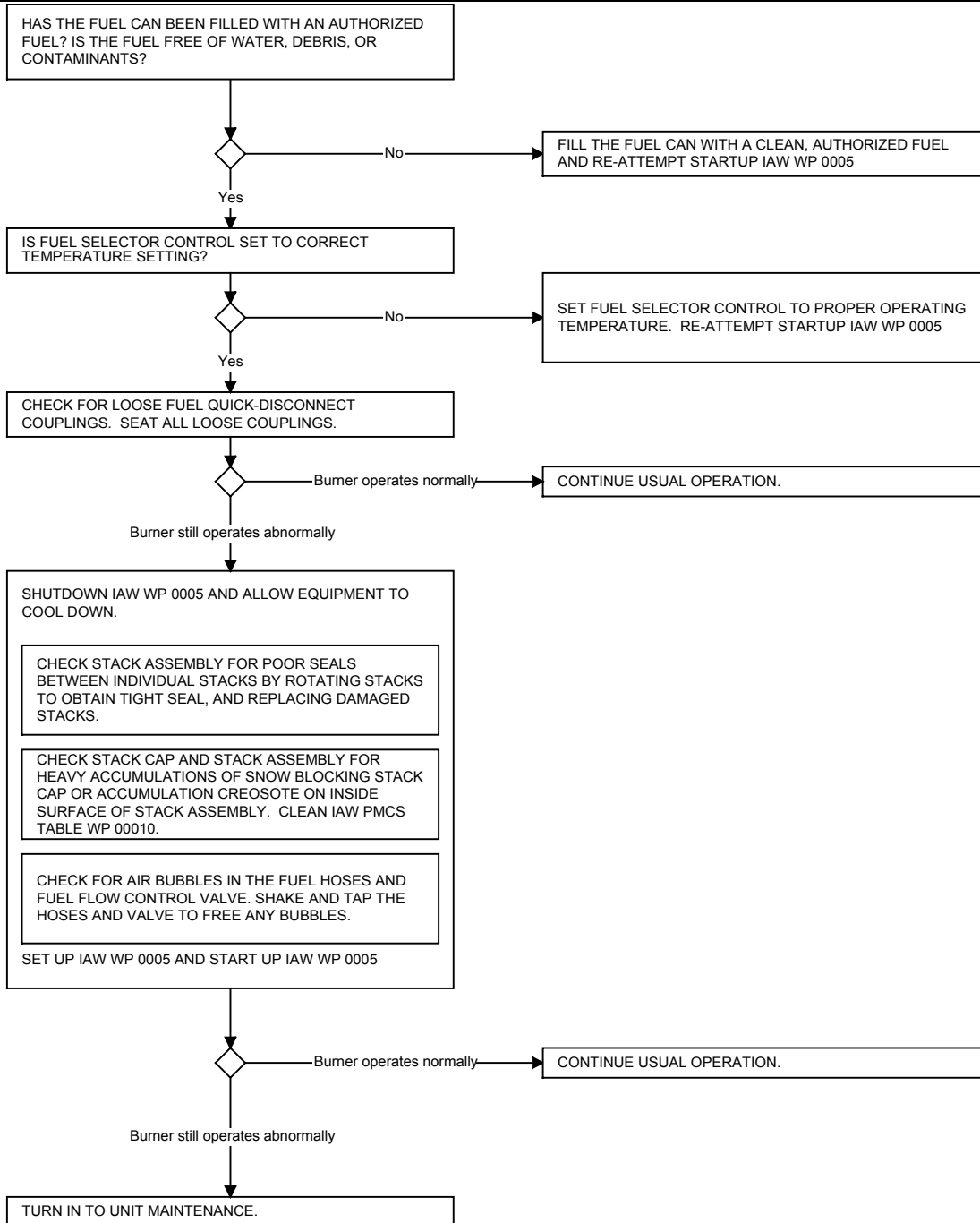

THIS PROCEDURE COVERS:
SOLID FUEL MODE: Fire Will Not Start Or Will Not Stay Lit

Maintenance Level
Operator

Materials/Parts
None

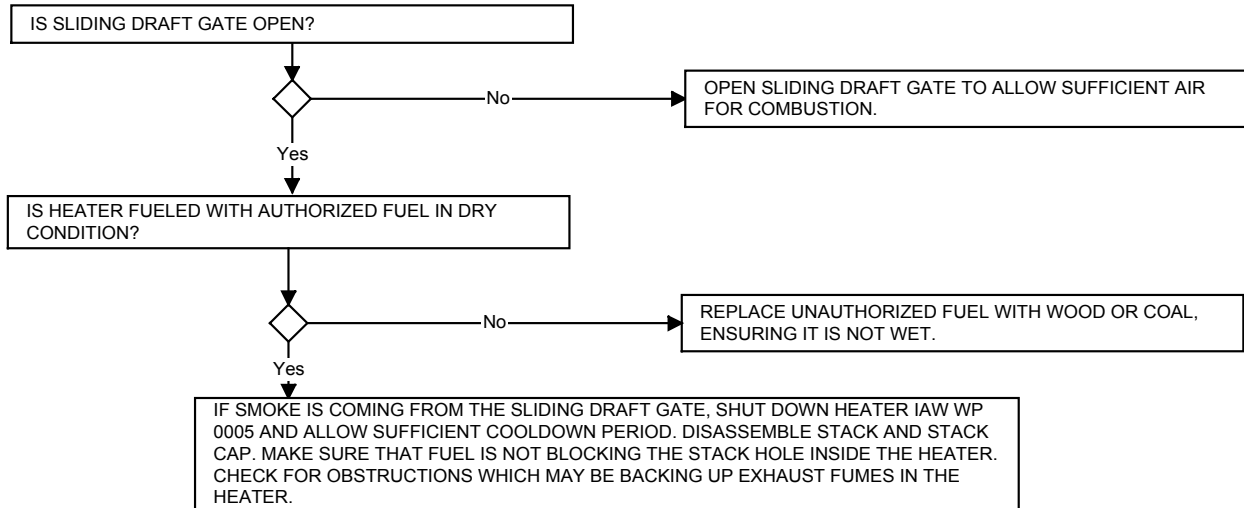

**SPACE HEATER ARCTIC (SHA)
TROUBLESHOOTING PROCEDURES**

0009 00

THIS PROCEDURE COVERS:
SOLID FUEL MODE: Excessive Smoke During Operation

Maintenance Level
Operator

Materials/Parts
None

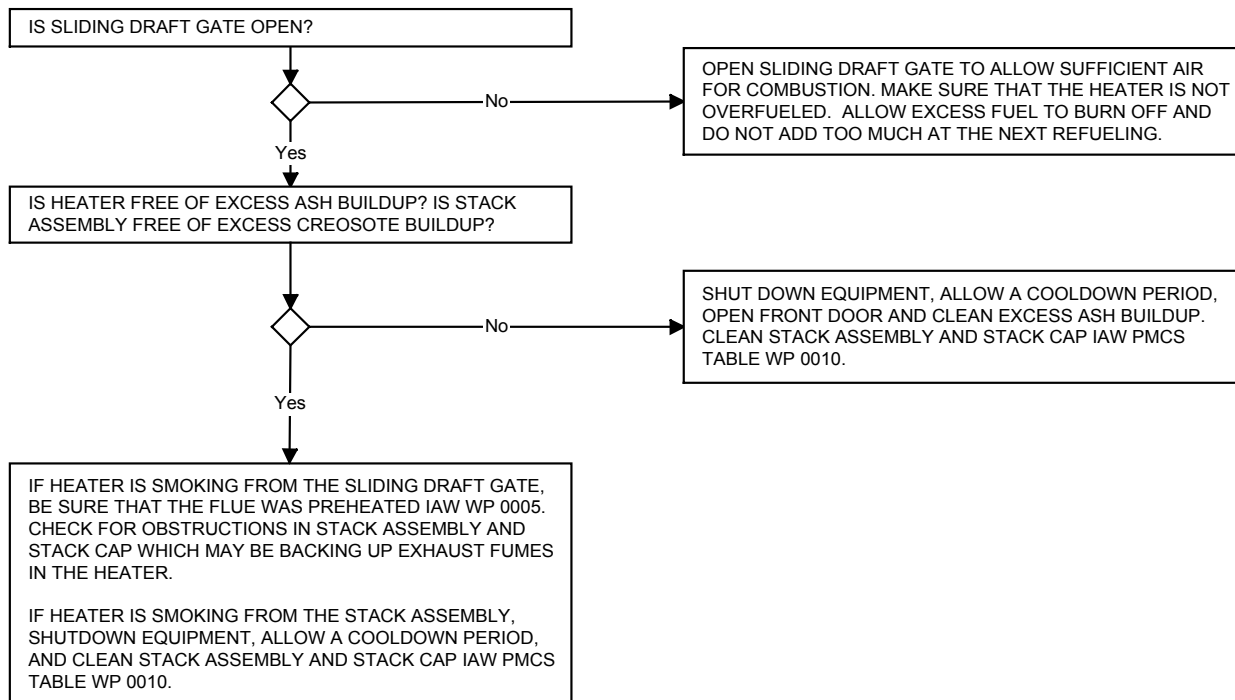

END OF WORK PACKAGE

THIS PAGE INTENTIONALLY LEFT BLANK

**SPACE HEATER ARCTIC (SHA)
PREVENTIVE MAINTENANCE CHECK AND SERVICES (PMCS) 0010 00**

THIS SECTION COVERS:
Introduction, PMCS Procedures

INITIAL SETUP:	
SHA Shut-down and cool	
Maintenance Level	Materials/Parts
Operator/Unit	Rags
Tools and Special Tools	(WP 0046, Table 1, Item 1)

INTRODUCTION

Preventive Maintenance Checks and Services (PMCS) are performed to keep the SHA and its associated equipment in good operating condition. The checks are used to find, correct, or report problems. Operator personnel are to do the PMCS jobs as shown in the PMCS table. PMCS are done every day the SHA is operated, using the PMCS table. Pay attention to WARNING and CAUTION statements. A WARNING means someone could be hurt. A CAUTION means equipment could be damaged.

Before you begin using the SHA, do **Before PMCS**

During use of the SHA, do **During PMCS**

After using the SHA, do **After PMCS**

Once a week, do **Weekly PMCS** if the SHA has been in use

Do **Monthly PMCS** once a month if the SHA has been in use

If you find something wrong when performing PMCS, fix it using troubleshooting and/or maintenance procedures.

The right-hand column of the PMCS table lists conditions that make the SHA not fully mission capable. Write up the faults that cannot be repaired on DA Form 2404 for unit maintenance. For further information on how to use this form, see DA PAM 738-750.

If tools that are required to perform PMCS are not listed in procedures, notify your superior.

INSPECTION

Look for signs of trouble. Senses help here. You can feel, smell, hear, or see many problems that can be eliminated before they get worse. Inspect to see if items are in good condition. Are components correctly installed and secured? Is any damage to the frame or components visible? Correct any faults or notify unit maintenance.

SPACE HEATER ARCTIC (SHA)

PREVENTIVE MAINTENANCE CHECK AND SERVICES (PMCS)

0010 00

There are some common items to check on the SHA and associated equipment. These include the following:

- Proper operation of SHA Fuel Control Valve
- Condition of Fuel Supply and Overflow Hoses and associated quick disconnect connectors
- Condition of Stack Assembly and Cap
- Accumulation of ash (if solid fuel used) in heater chamber

LUBRICATION SERVICE INTERVALS

The door hinge and latch assembly should be lubricated with a light machine oil or WD-40 when stored.

All metal heater components should be wiped down with a rag dampened with a light machine oil or WD-40 before storage or after cleaning to prevent rust.

CLEANING

Proper cleaning of the SHA and components is an integral part of maintenance. It will help prevent possible problems in the future, so make it a habit to clean the SHA and its components whenever necessary.

The heater frame interior can be cleaned with a rag; the exterior can be cleaned with a brush. Wipe down all hoses with a rag. Make sure that all connectors are free of debris and that they work freely.



WARNING!
Stack Fire

When operating the heater in solid fuel mode, a buildup of creosote can accumulate on the inside surface of the stack assembly that may result in a fire inside the stack. To prevent creosote buildup when operating with solid fuel, the stack assembly should be cleaned daily. Failure to do so may result in severe injury or death.

After operating the heater in solid fuel mode, be sure to clean the inside of the stack assembly sections with a rag or brush to remove any creosote buildup that may occur.

SPACE HEATER ARCTIC (SHA)

PREVENTIVE MAINTENANCE CHECK AND SERVICES (PMCS)

0010 00

THIS SECTION COVERS:

Before Operation PMCS Checks and Services

INITIAL SETUP:

SHA Shutdown and Cool

Maintenance Level

Operator

Materials

Wiping Rags (WP0046, Table 1, Item 1)

Table 1. Preventive Maintenance Checks and Services for SHA

ITEM NO.	INTERVAL	ITEM TO BE CHECKED OR SERVICED	PROCEDURE	EQUIPMENT NOT READY/ AVAILABLE IF:
WHEN OPERATING WITH EITHER LIQUID OR SOLID FUEL...				
1	Before	Stack cap and nested stack assemblies	 WARNING! Stack Fire When operating the heater in solid fuel mode, a buildup of creosote can accumulate on the inside surface of the stack assembly that may result in a fire inside the stack. To prevent creosote buildup when operating with solid fuel, the stack assembly should be cleaned daily with a brush or rag. Failure to do so may result in a fire causing severe injury or death. Check inside of stack sections (1) and stack cap (2) for thick deposits of carbon/soot or creosote, and clean if necessary. Check for cracked sections or bent flanges which may cause the leakage of exhaust gases into heated space during heater operation.	Stack or stack cap assembly have an accumulation of carbon/soot or creosote buildup which would impair operation or cause a fire inside the stack and stack cap during operation.
2	Before	Tent lines and wire ropes	Check for frayed or cut tent lines (3) and wire ropes (4).	Tent lines or wire ropes frayed or cut.
3	Before	Heater body assembly	Clean ash deposits from heater body assembly (5) if unit was recently used in solid fuel mode. Check that door (6) and lid assemblies (7) open and shut properly, and that stack adaptor assembly (8) is not bent.	Ash deposits from last operation in solid fuel mode have not been removed; door and lid assemblies do not open, or do not shut fully; stack adaptor assembly will not accommodate stack assembly.
4	Before	Burner cover assembly	Check that burner cover assembly (9) is not bent, and that it does not have holes in it.	Burner cover assembly bent or has holes in it which would prevent it from sealing off air leaks in liquid or solid fuel operation.

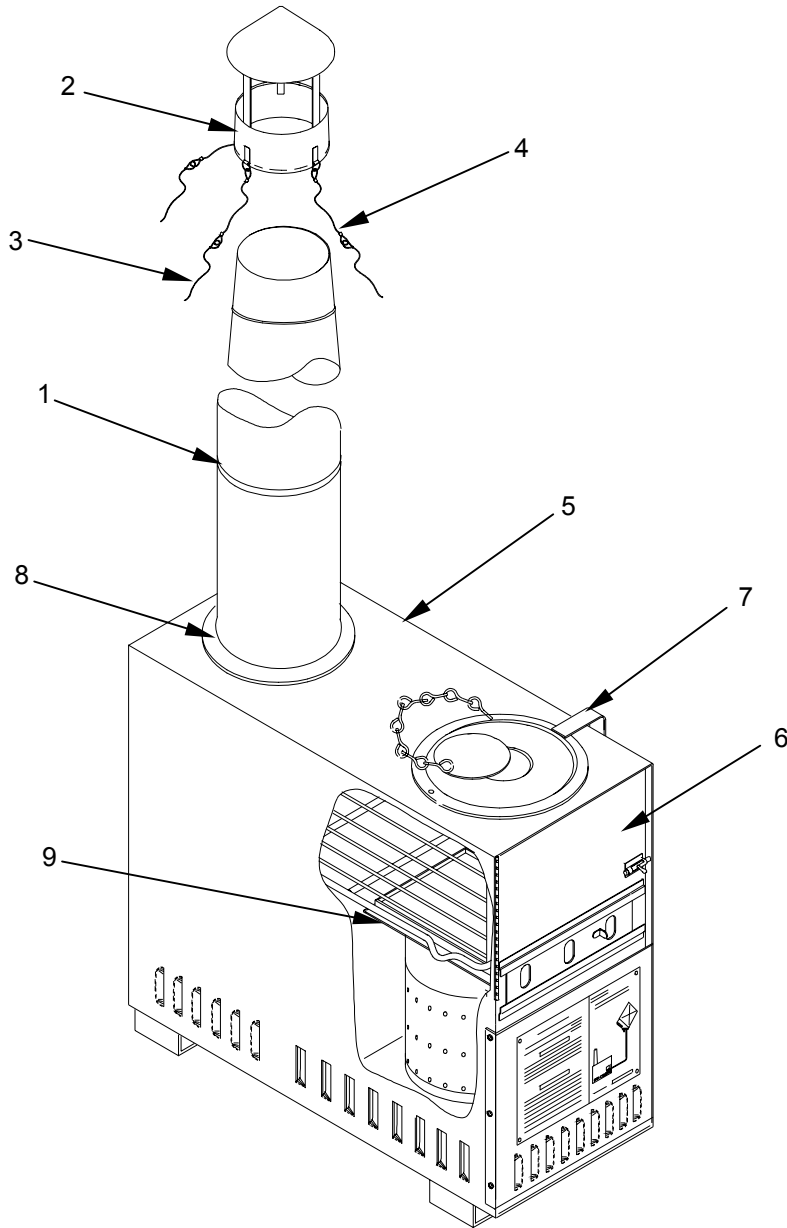

SPACE HEATER ARCTIC (SHA)

PREVENTIVE MAINTENANCE CHECK AND SERVICES (PMCS)

0010 00

THIS SECTION COVERS:

Before Operation PMCS Checks and Services

INITIAL SETUP:

SHA Shutdown and Cool

Maintenance Level

Operator

Materials

Wiping Rags (WP0046, Table 1, Item 1)

Table 1. Preventive Maintenance Checks and Services for SHA - continued

ITEM NO.	INTERVAL	ITEM TO BE CHECKED OR SERVICED	PROCEDURE	EQUIPMENT NOT READY/ AVAILABLE IF:
WHEN OPERATING WITH LIQUID FUEL...				
5	Before	Burner shell assembly	Check down tube assembly (1) and inside of burner shell assembly (2) for thick carbon/soot deposits. Clean if necessary. Check both assemblies, (1) and (2) , for cracked metal.	Down tube assembly is cracked or plugged and/or burner assembly holes are blocked.
6	Before	Fuel flow control valve	Check for bent/damaged bracket (3) , fuel flow control valve (4) , cup/cable assembly (5) . Be sure bracket (3) is not bent out of the required 90 degree position from the heater body assembly (6) .	Valve is damaged or valve bracket bent out of 90 degree position with heater body.
7	Before	Fuel hoses	Check for cuts or swollen areas in hose (7) walls or damaged fittings (8) .	Hoses are cut or have swollen areas, or fittings are damaged.
8	Before	Fuel can stand, fuel can	Check fuel can stand (9) and fuel can (10) for damage.	Fuel can stand is unstable; fuel can leaks.
9	Before	Gravity feed adaptor	Check gravity feed adaptor (11) for damage. Ensure that the gasket (12) inside the cap has been installed. Check the QD fitting (13) for dirt, ice, or other foreign objects; clean if necessary. Check hose (14) for cracks or damaged areas.	Gravity feed adaptor leaks.
WHEN OPERATING WITH SOLID FUEL...				
10	Before	Solid fuel grate	Check that solid fuel grate (15) is not bent or otherwise damaged.	Solid fuel grate is bent such that it allows fuel to touch bottom.
11	Before	Sliding draft gate	Check that sliding draft gate (16) opens and shuts completely, and that when shut, it forms a tight seal.	Sliding draft gate will not fully shut, or does not open.

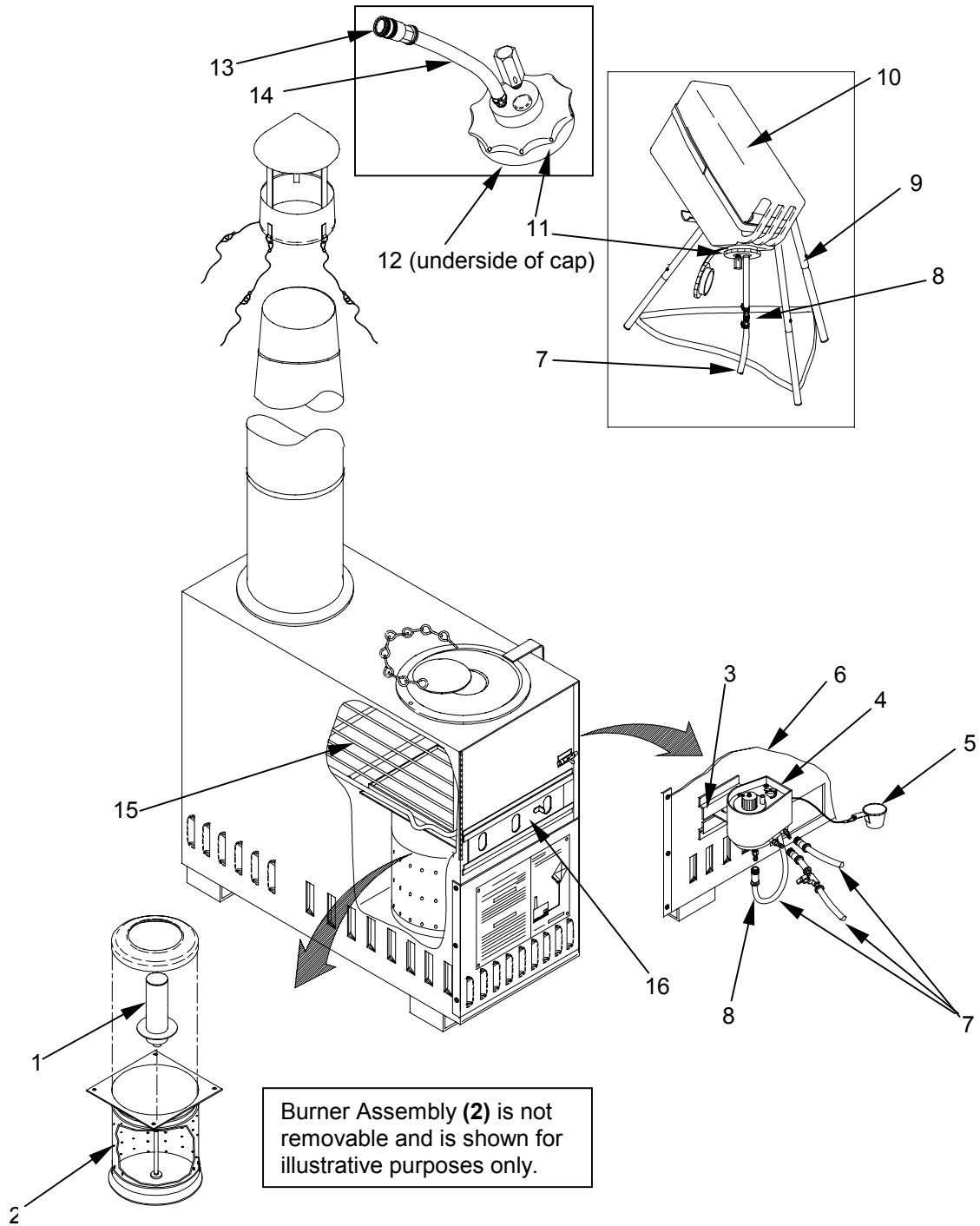

SPACE HEATER ARCTIC (SHA)

PREVENTIVE MAINTENANCE CHECK AND SERVICES (PMCS)

0010 00

THIS SECTION COVERS:

During Operation PMCS Checks and Services

INITIAL SETUP:

SHA Shutdown and Cool

Maintenance Level

Operator

Table 1. Preventive Maintenance Checks and Services for SHA - continued

ITEM NO.	INTERVAL	ITEM TO BE CHECKED OR SERVICED	PROCEDURE	EQUIPMENT NOT READY/ AVAILABLE IF:
WHEN USING EITHER LIQUID OR SOLID FUEL . . .				
12	During	Nested stack assembly	Check stack assembly (1) for smoke leakage inside heated space.	Stack assembly leaks smoke into heated space.
13	During	Heater body assembly	Check heater body (2) for smoke leakage inside heated space.	Heater body leaks smoke into operating space.
WHEN USING LIQUID FUEL . . .				
14	During	Fuel flow control valve	Check fuel flow control valve (3) for fuel leakage.	Valve leaks fuel.
15	During	Fuel hoses	Check hose (4) walls and fittings (5) for fuel leakage.	Hoses leak fuel.
16	During	Fuel can, gravity feed adaptor	Check fuel can (6) and gravity feed adaptor (7) for fuel leakage.	Fuel can or adaptor leak fuel.
WHEN USING SOLID FUEL . . .				
No 'DURING' PMCS in solid fuel mode.				

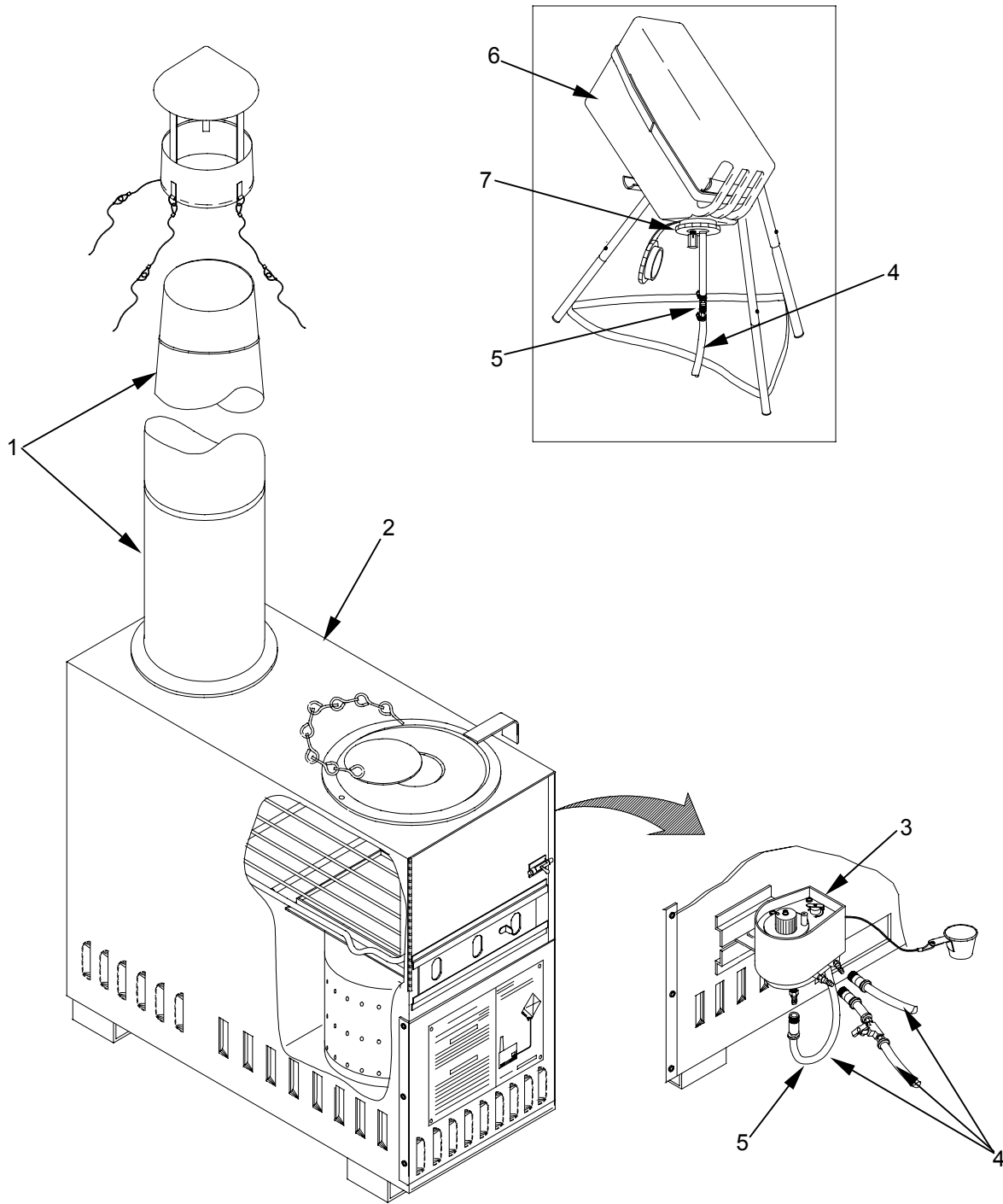

SPACE HEATER ARCTIC (SHA)

PREVENTIVE MAINTENANCE CHECK AND SERVICES (PMCS)

0010 00

THIS SECTION COVERS:

After Operation PMCS Checks and Services

INITIAL SETUP:

SHA Shutdown and Cool

Maintenance Level

Operator

Materials

Wiping Rags (WP0046, Table 1, Item 1)

Table 1. Preventive Maintenance Checks and Services for SHA - continued

ITEM NO.	INTERVAL	ITEM TO BE CHECKED OR SERVICED	PROCEDURE	EQUIPMENT NOT READY/ AVAILABLE IF:
WHEN USING EITHER LIQUID OR SOLID FUEL. . .				
17	After	Stack cap and nested stack assemblies	Check inside of stack sections (1) and stack cap (2) for thick deposits of carbon/soot, and clean if necessary. Check for cracked sections or bent flanges which may cause the leakage of exhaust gases into heated space during operation.	Stack or stack cap assembly have an amount of soot or carbon buildup which would impair operation or cause a fire inside the stack and stack cap during operation.
18	After	Tent lines and wire ropes	Check for frayed or cut tent lines (3) and wire ropes (4).	Tent lines or wire ropes frayed or cut.
19	After	Heater body assembly	Clean ash deposits from heater body assembly (5) if unit was recently used in solid fuel mode. Check that door (6) and lid assemblies (7) open and shut properly, and that stack adaptor assembly (8) is not bent.	Door and lid assemblies do not open, or do not shut fully; stack adaptor assembly will not accommodate stack assembly.
20	After	Burner cover assembly	Check that burner cover assembly (9) is not bent, and that it does not have holes in it.	Burner cover assembly bent or has holes in it which would prevent it from sealing off air leaks in liquid or solid fuel operation.

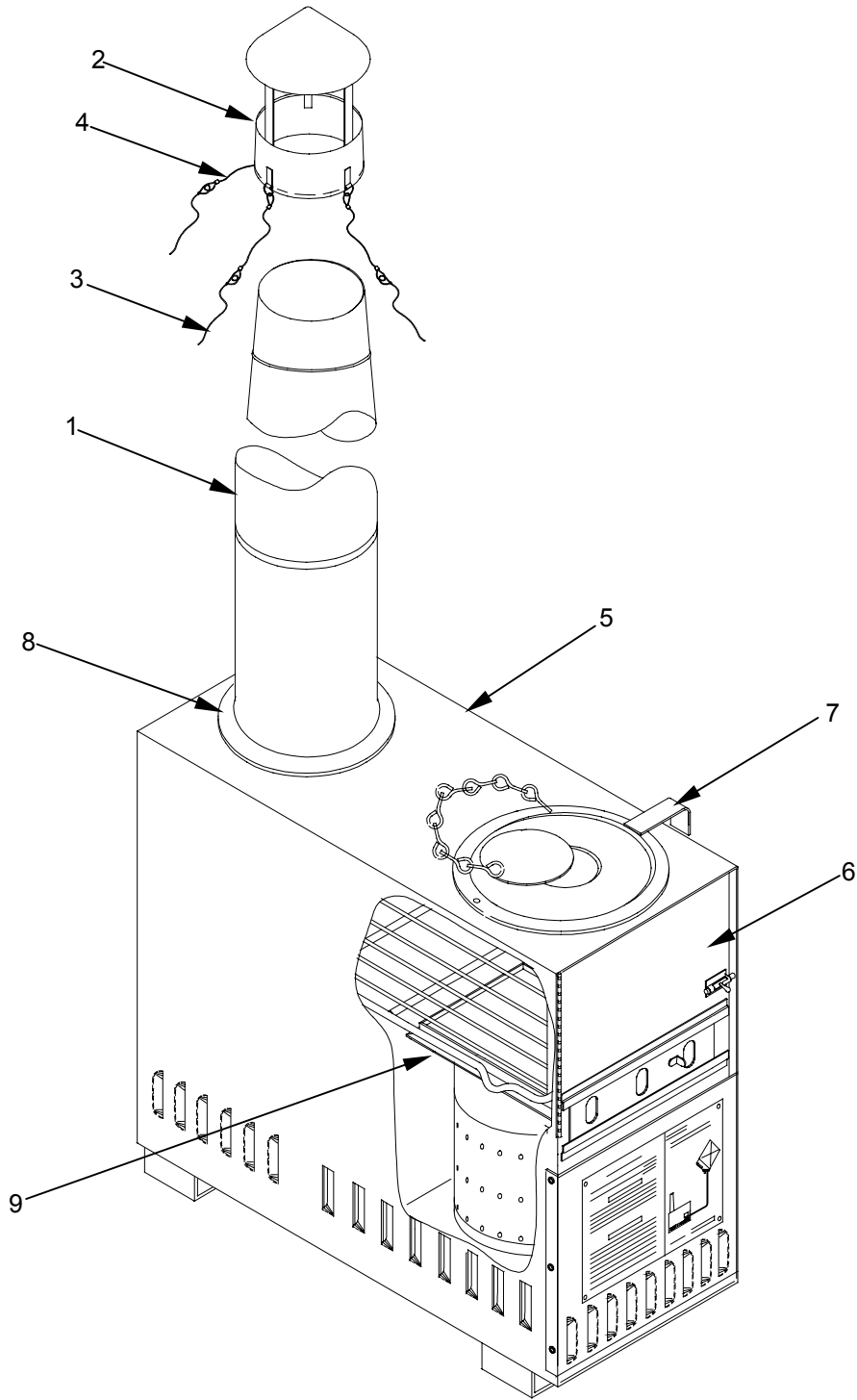

SPACE HEATER ARCTIC (SHA)

PREVENTIVE MAINTENANCE CHECK AND SERVICES (PMCS)

0010 00

THIS SECTION COVERS:

After Operation PMCS Checks and Services

INITIAL SETUP:

SHA Shutdown and Cool

Maintenance Level

Operator

Materials

Wiping Rags (WP0046, Table 1, Item 1)

Table 1. Preventive Maintenance Checks and Services for SHA - continued

ITEM NO.	INTERVAL	ITEM TO BE CHECKED OR SERVICED	PROCEDURE	EQUIPMENT NOT READY/ AVAILABLE IF:
WHEN USING LIQUID FUEL. . .				
21	After	Burner shell assembly	Check down tube assembly (1) and inside of burner shell assembly (2) for thick carbon/soot deposits. Clean if necessary. Check both assemblies, (1) and (2), for cracked metal.	Down tube assembly is cracked or plugged and/or burner assembly holes are blocked.
22	After	Fuel flow control valve	Check for bent/damaged bracket (3), fuel flow control valve (4), cup/cable assembly (5). Be sure bracket (3) not bent out of the required 90 degree position from the heater body assembly (6). Drain fuel and clean filter.	Valve is damaged or valve bracket bent out of 90 degree position with heater body.
23	After	Fuel hoses	Check for cuts or swollen areas in hose (7) walls or damaged fittings (8).	Hoses are cut or have swollen areas, or fittings are damaged.
24	After	Fuel can stand, fuel can	Check fuel can stand (9) and fuel can (10) for damage.	Fuel can stand is unstable; fuel can leaks.
25	After	Gravity feed adaptor	Check gravity feed adaptor (11) for damage. Ensure that the gasket (12) on the underside of the cap has been installed. Check the QD fitting (13) for dirt, ice, or other foreign objects; clean if necessary. Check hose (14) for cracks or damaged areas.	Gravity feed adaptor leaks.
WHEN USING SOLID FUEL. . .				
26	After	Heater body assembly	Clean ash deposits from heater body assembly (6).	Ash deposits from last operation in solid fuel mode have not been removed.
27	After	Solid fuel grate	Check that solid fuel (15) grate is not bent or otherwise damaged.	Solid fuel grate is bent such that it allows fuel to touch bottom.
28	After	Sliding draft gate	Check that sliding draft gate (16) opens and shuts completely, and that when shut, it forms a tight seal.	Sliding draft gate will not fully shut, or does not open.

SPACE HEATER ARCTIC (SHA)
PREVENTIVE MAINTENANCE CHECK AND SERVICES (PMCS)

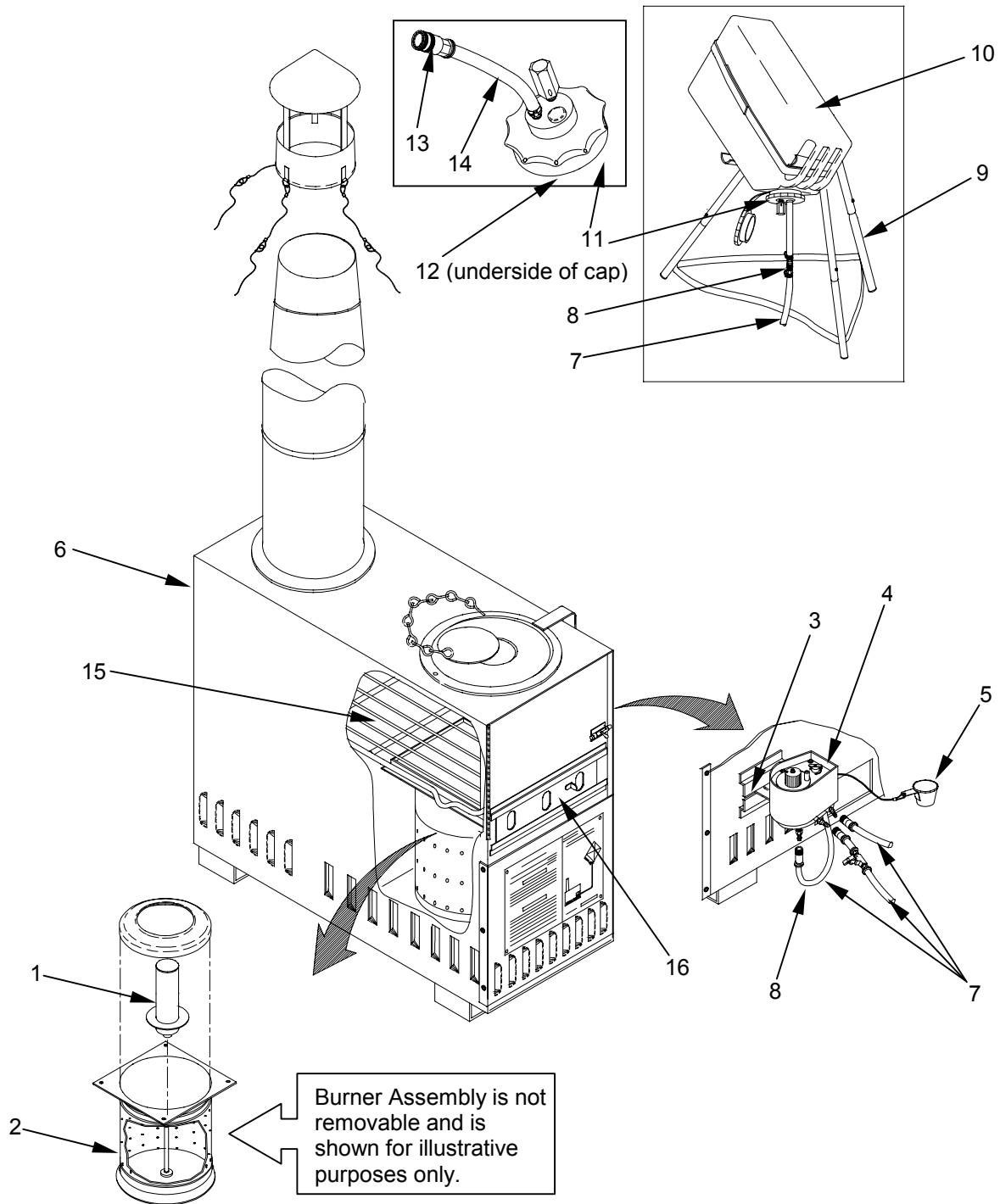

SPACE HEATER ARCTIC (SHA)

PREVENTIVE MAINTENANCE CHECK AND SERVICES (PMCS)

0010 00

MANDATORY REPLACEMENT PARTS

The Space Heater Arctic has no mandatory replacement parts.

END OF WORK PACKAGE

THIS PAGE INTENTIONALLY LEFT BLANK

THIS SECTION COVERS:

Operator Maintenance

INITIAL SETUP

SHA shutdown and cool

Maintenance Level

Operator

INTRODUCTION

This section contains Operator Maintenance applicable to the SHA as authorized by the Maintenance Allocation Chart (MAC) in WP 0025 of this manual.

All maintenance procedures in this section can be performed by one person unless otherwise indicated.

Read all **WARNING's**, **CAUTION's**, and **NOTE's** carefully before attempting the procedures. This includes the warnings at the front of this manual.

Each maintenance item will include a heading which lists the action to be taken, the tools and parts/materials required, and the condition the equipment must be in to perform the action.

INSPECT

Operator Maintenance for the Space Heater Arctic is limited to those tasks outlined in "Table 1, Preventive Maintenance Checks and Services for SHA" of Work Package 0010.

END OF WORK PACKAGE

THIS PAGE INTENTIONALLY LEFT BLANK

TM 10-4520-261-12&P

CHAPTER 4

**UNIT MAINTENANCE INSTRUCTIONS
FOR
SPACE HEATER ARCTIC**

THIS PAGE INTENTIONALLY LEFT BLANK

SERVICE UPON RECEIPT**GENERAL**

The heaters are shipped in standard type corrugated cardboard boxes. All components to the heaters are stowed within the heater body. The Unit Maintenance technician should inspect the equipment before it is used. Following is a list of functions which must be performed upon receipt of the SHA:

Unpacking. Before operation, heaters must be unpacked and cleaned of packing material and other foreign debris, and serviced in accordance with PMCS Table 1, WP 0010.

Inspection. The equipment must be inspected for damage incurred during shipment. If the equipment has been damaged in shipment, report the damage on SF 364, Report of Discrepancy.

Packing list verification. Check the equipment against the packing list to see if the shipment is complete. Report all discrepancies in accordance with DA Pam 738-750.

Verification of equipment modifications. Check to see whether the equipment has been modified.

Pre-operation services. Service damaged equipment, as necessary, using Unit Maintenance procedures in Chapter 4 to restore equipment to operable condition.

Break-in Period. The Space Heater Arctic should be set up and operated for a break-in period of 1 to 2 hours in a well ventilated area so that any fumes generated by newly painted parts can flash off.

THIS PAGE INTENTIONALLY LEFT BLANK

TROUBLESHOOTING PROCEDURES

The Malfunction Index lists common malfunctions that may occur during heater inspection and operation.

Find the malfunction the heater is having in the index and go to the given troubleshooting paragraph in the following pages.

These charts cannot list all malfunctions that may occur, all tests or all inspections needed to find the fault, nor all actions required to correct the fault. If your malfunction is not listed in, or is not correctable through, this troubleshooting index, notify Unit Maintenance.

DO NOT START THE TASK UNTIL:

- You understand the task
- You understand what you are to do
- You understand what is needed to do the work
- You have the things you need

MALFUNCTION SYMPTOM INDEX

Malfunction or Symptom	Refer to Troubleshooting Procedure
LIQUID FUEL MODE	
Heater does not start or sputters and misfires during operation	1
SOLID FUEL MODE	No Troubleshooting procedures for Solid Fuel mode at the Unit level. If Operator Troubleshooting did not correct the problem, replace the heater.

**SPACE HEATER ARCTIC (SHA)
UNIT TROUBLESHOOTING PROCEDURES**

0013 00

THIS PROCEDURE COVERS:

LIQUID FUEL MODE: Heater Does Not Start or Sputters and Misfires During Operation

INITIAL SETUP:

SHA Shutdown and Cool

Maintenance Level

Unit

Materials/Parts

None

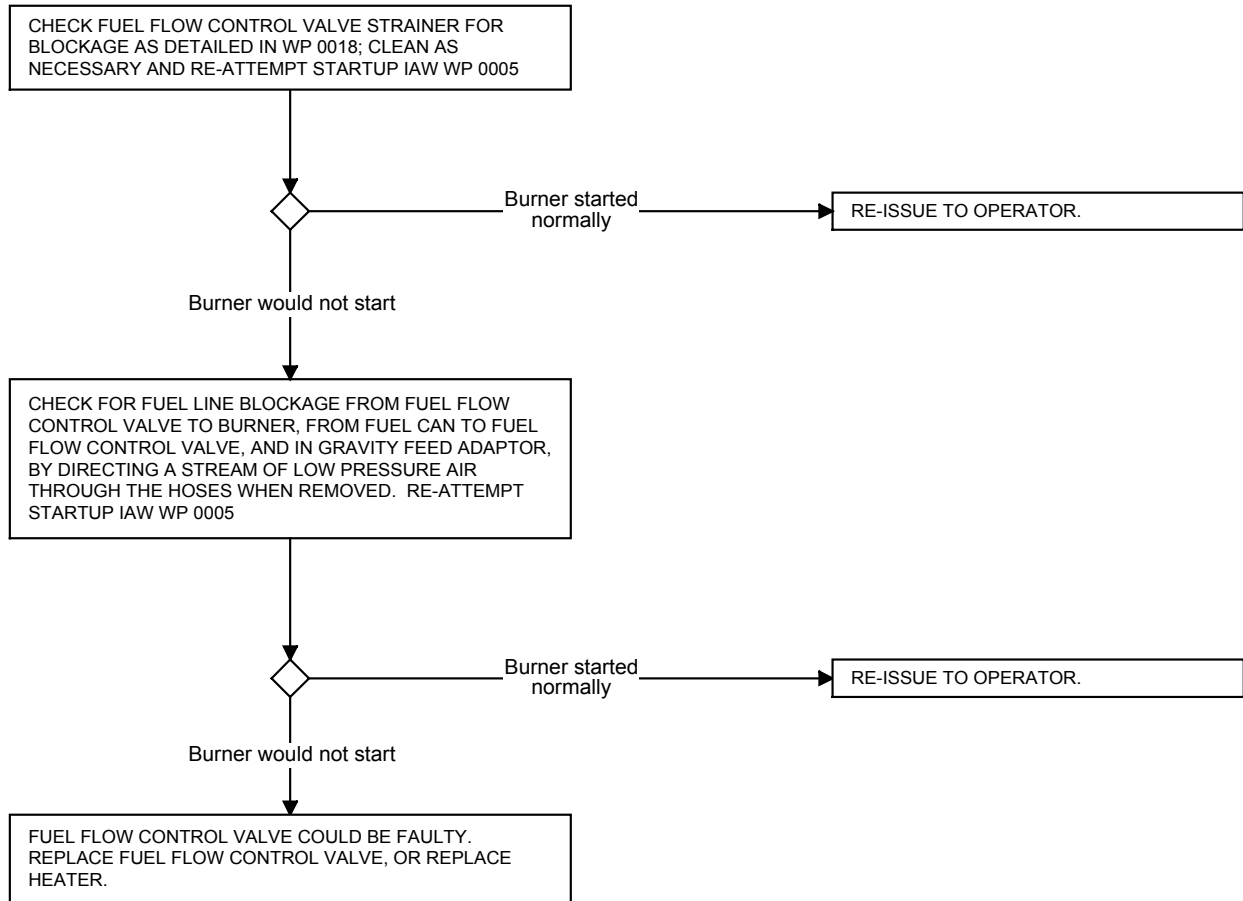

END OF WORK PACKAGE

CLEANING**THIS SECTION COVERS:**

Service

INITIAL SETUP

SHA shut-down and cool (WP 0005)

Maintenance Level

Unit

Materials/Parts

Rags (WP 0046, Table 1, Item 1)

Tools and Special Tools

General Mechanic Tool Kit (WP 0025, Table 2, Item 1)

GENERAL. This procedure is for cleaning the following SHA items: stack cap assembly, stack assembly, burner body assembly, lid assembly, solid fuel grate, burner cover, fuel flow control valve, hoses, and Down-tube assembly.

**WARNING!****Fire or Explosion****Possible Equipment Damage**

Certain heater components could be damaged by scraping or brushing. These components could malfunction and result in injury to personnel (for example, fuel hoses could be damaged resulting in fuel leakage and fire).

Scrape or brush. Use a scraping tool and wire brush to remove all hardened deposits of soot, resin, or other foreign matter from the stack, lid assembly, solid fuel grate, and burner body components, inside and out.

Do not scrape or brush any rubber or plastic parts, instruction or I.D. plates, fuel flow control valve labeling or sightglass.

Clean under the fire ring of the burner assembly with a brush or dry rag. Carbon may build up under the fire ring after a period of use.

Wash. Wash exterior of heater and subassemblies (fuel flow control valve, all hoses, Down-tube assembly, etc.) with a cloth and mildly soapy water. Wipe all surfaces to remove any soot or other residues. Wash interior of heater body, burner shell assembly, stack cap assembly, and stack assembly with a cloth and mildly soapy water. Wipe all surfaces to remove any soot or other residue.

On the inside and outside of the heater body, stack cap assembly, and stack assembly, scrape or wire brush any dirt buildups which will not come off by washing.

Dry heater body and metal components with a dry rag. Wipe down all metal components with a rag dampened with a light machine oil or WD-40 type product or they will rust.

END OF WORK PACKAGE

THIS PAGE INTENTIONALLY LEFT BLANK

DENT REMOVAL**THIS SECTION COVERS:**

Service

INITIAL SETUP

SHA shut-down and cool (WP 0005)

Maintenance Level

Unit

Materials/Parts**Tools and Special Tools**General Mechanic Tool Kit (WP 0025, Table 2, Item 1)

GENERAL

This procedure is for dent removal on the following SHA items: stack cap assembly, stack assembly, burner body, rear door, and burner cover.

**WARNING!****Carbon Monoxide**

Bent or dented components may allow deadly carbon monoxide emissions into the operating space. Do not attempt to repair these components if leakage will not be completely stopped, or death may result due to inhalation of excessive amounts of carbon monoxide.

REPAIR

Use common tools (pliers, mallets, etc.) to remove, to the extent possible, any dents which impair operation of the heater.

Dent removal should only be carried out on the burner body, door and lid assemblies, stack cap and telescoping stack assemblies.

Dent removal should be done short of replacing the item or items if and only if equipment operation will not be reduced (ie: if dent removal does not stop smoke leakage into the heated space, the faulty component or entire heater should then be replaced).

END OF WORK PACKAGE

THIS PAGE INTENTIONALLY LEFT BLANK

STACK CAP ASSEMBLY WIRE ROPES AND TENT LINES**THIS SECTION COVERS:**

Replace

INITIAL SETUP

SHA shut-down and cool (WP 0005)

Maintenance Level

Unit

Tools and Special Tools

General Mechanic Tool Kit (WP 0025, Table 2, Item 1)

Swaging Tool (WP 0025, Table 2, Item 2)

Materials/Parts

Rope, wire (WP 0046, Table 1, Item 8)

Sleeves, (WP 0046, Table 1, Item 9)

Rope, nylon (WP 0046, Table 1, Item 10)

REPLACE WIRE ROPE(S).

Cut unserviceable wire rope **(1)** from stack cap assembly **(2)**.

Cut 12 inch (30.5 centimeter) section of serviceable wire rope **(1)** from bulk wire rope supply.

Thread approximately 1 ½ inches (3.81 centimeters) of one end of wire rope **(1)** through a swaging sleeve **(3)**.

Thread the same end of the wire rope **(1)** through the stack cap assembly **(2)** perforation, and then back through the swaging sleeve **(3)** (a ¾ inch [1.91 centimeter] loop should be formed).

Crimp the swaging sleeve **(3)** down on the wire ropes **(1)** so that the loop is permanently closed.

Thread approximately 1-½ inches (3.81 centimeters) of the opposite end of wire rope **(1)** through the other swaging sleeve **(3)**.

Thread this same end of wire rope **(1)** back through the the swaging sleeve **(3)** (a ¾ inch [1.91 centimeter] loop should be formed).

Crimp the swaging sleeve **(3)** down on the wire ropes **(1)** so that the loop is permanently closed.

Repeat, as necessary, for other two wire ropes.

REPLACE TENT LINE(S).

Cut unserviceable tent line **(4)** from wire rope **(1)**.

Cut 13 foot (4 meter) section of serviceable tent line **(4)** and tie to wire rope **(1)**.

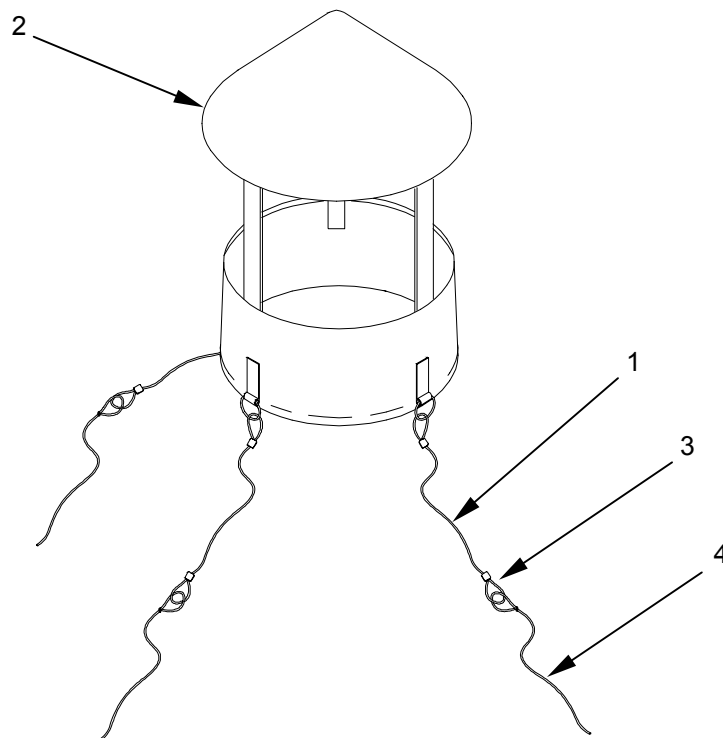

END OF WORK PACKAGE

FUEL HOSES AND GRAVITY FEED ADAPTOR

THIS WORK PACKAGE COVERS:

Inspect and Replace

INITIAL SETUP

SHA shut-down and cool (WP 0005)

Maintenance Level

Unit

Tools and Special Tools

Materials/Parts

Gasket, rubber (WP 0046, Table 1, Item 4)

INSPECT

Inspect the Gravity Feed Adaptor cap **(1)** for any cracks that would cause a fuel leak. Inspect the gasket **(2)** inside the adaptor for any cracks that would prevent a proper seal. Inspect the hose **(3)** and QD connector **(4)** at the top of the adaptor to ensure that they are securely connected and that the hoses are not cracked or otherwise damaged. Check the condition of the automatic vent **(5)** for proper operation.

Inspect the fuel supply hose **(6)** for any cracking or other deterioration that would cause the hose to leak. Check the condition of all connections **(7)** between the hose and the quick disconnect fittings **(8)** for a secure seal.

Inspect the overflow hose **(9)** for any cracking or other deterioration that would cause the hose to leak. Check the condition of the connection **(10)** between the hose and the quick disconnect fitting **(11)** for a secure seal.

REPLACE

Replace a cracked or otherwise damaged gravity feed adaptor gasket **(2)** by removing the damaged gasket and pressing a new gasket in place.

Replace the gravity feed adaptor if there are cracks in the plastic cap, the hose is damaged, or the QD connector leaks.

Replace the fuel supply hose or overflow hose if there are any cuts or damage that would cause the hose to leak. Replace if the QD connectors or any of the fittings are damaged or leak.

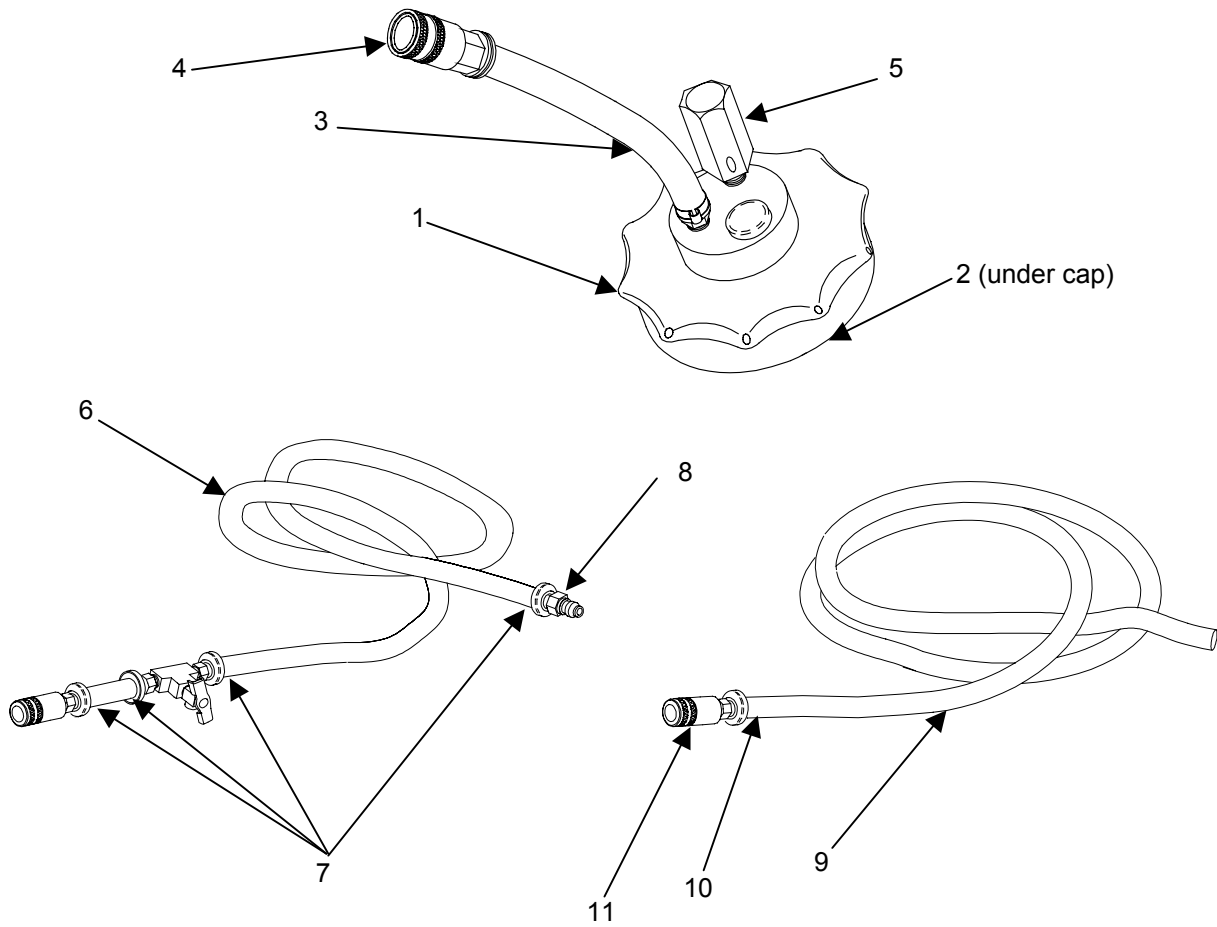

END OF WORK PACKAGE

FUEL FLOW CONTROL VALVE FUEL STRAINER**THIS SECTION COVERS:**

Service and Replace

INITIAL SETUP

SHA shut-down and cool (WP 0005)

Maintenance Level

Unit

Tools and Special ToolsGeneral Mechanic Tool Kit
(WP 0025, Table 2, Item 1)**Materials/Parts**Strainer (WP 0046, Table 1, Item 6)
Gasket, Cork (WP 0046, Table 1, Item 7)
Solvent, Dry Cleaning (WP 0046, Table 1, Item 2)**REMOVE**

Remove strainer **(1)** from fuel flow control valve **(2)** by rotating counter-clockwise with a screwdriver.
Remove cork gasket **(3)**.

INSPECT

Inspect strainer **(1)** for sediment or other obstructions. If unserviceable, obtain a serviceable strainer **(1)**, skip "CLEAN" procedures, and proceed to "REPAIR".

CLEAN

If necessary, clean the strainer **(1)** to remove dirt or other obstructions.

**WARNING!****Fire and Injury To Personnel**

Dry Cleaning Solvent P-D-680 is dangerous to personnel and property, and has a low flash point (100 to 138 degrees Fahrenheit [38 to 59 degrees Celsius]). Avoid skin contact by wearing rubber gloves and do not use the solvent near open flame or in areas where temperatures exceed the flash point.

Mix Dry Cleaning Solvent to specifications on product container.

Allow strainer **(1)** to soak in the solution to loosen sediment.

Remove strainer **(1)** from solution, blow off excess and allow to air dry.

INSTALL

Install serviceable cork gasket (3). Thread serviceable strainer (1) into fuel flow control valve (2). Be careful not to cross-thread strainer (1), and screw in hand tight.

Tighten the strainer (1) into the fuel flow control valve (2) approximately 1 ½ to two full turns. Be careful not to over tighten the strainer.

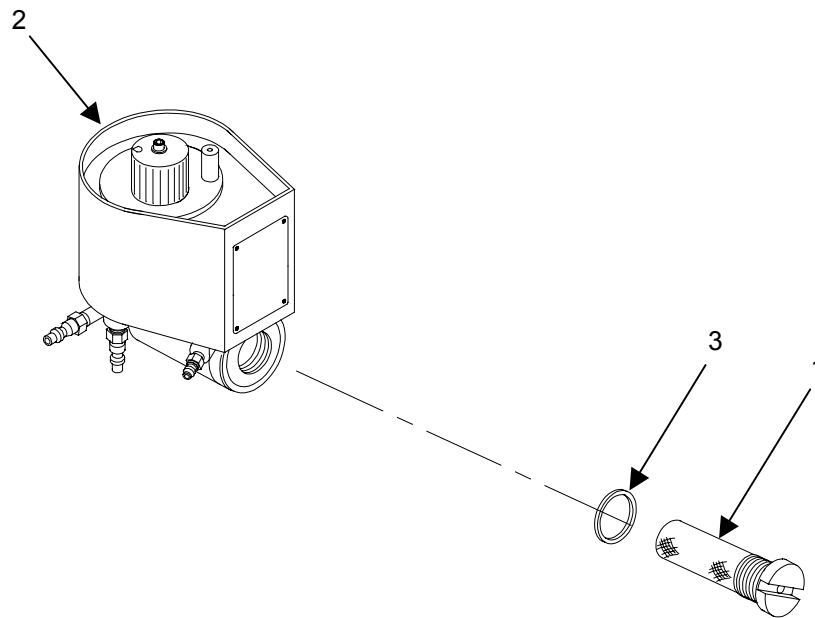
**END OF WORK PACKAGE**

FUEL FLOW CONTROL VALVE CUP/CABLE ASSEMBLY**THIS SECTION COVERS:**

Service and Replace

INITIAL SETUP

SHA shut-down and cool (WP 0005)

Maintenance Level

Unit

Tools and Special Tools

General Mechanic Tool Kit (WP 0025, Table 2, Item 1)

Swaging Tool (WP 0025, Table 1, Item 3)

Wire Cutters (WP 0025, Table 1, Item 2)

Materials/Parts

Rope, wire (WP 0046, Table 1, Item 8)

Sleeve, swaging (WP 0046, Table 1, Item 9)

REPLACE

Cut unserviceable wire rope **(1)** from priming cup **(2)** and from fuel flow control valve bracket **(3)**.

Cut 16 inch (40.6 centimeter) section of serviceable wire rope **(1)** from bulk wire rope supply.

Thread approximately 1 ½ inches (3.81 centimeters) of one end of wire rope **(1)** through a swaging sleeve **(4)**.

Thread the same end of the wire rope **(1)** through the priming cup **(2)** perforation, and then back through the swaging sleeve **(4)** (a ¾ inch [1.91 centimeter] loop should be formed).

Crimp the swaging sleeve **(4)** down on the wire ropes **(1)** so that the loop is permanently closed.

Thread approximately 1 ½ inches (3.81 centimeters) of the opposite end of wire rope **(1)** through the other swaging sleeve **(4)**.

Thread this same end of wire rope **(1)** through the fuel flow control valve bracket **(3)** perforation, and then back through the swaging sleeve **(4)** (a ¾ inch [1.91 centimeter] loop should be formed).

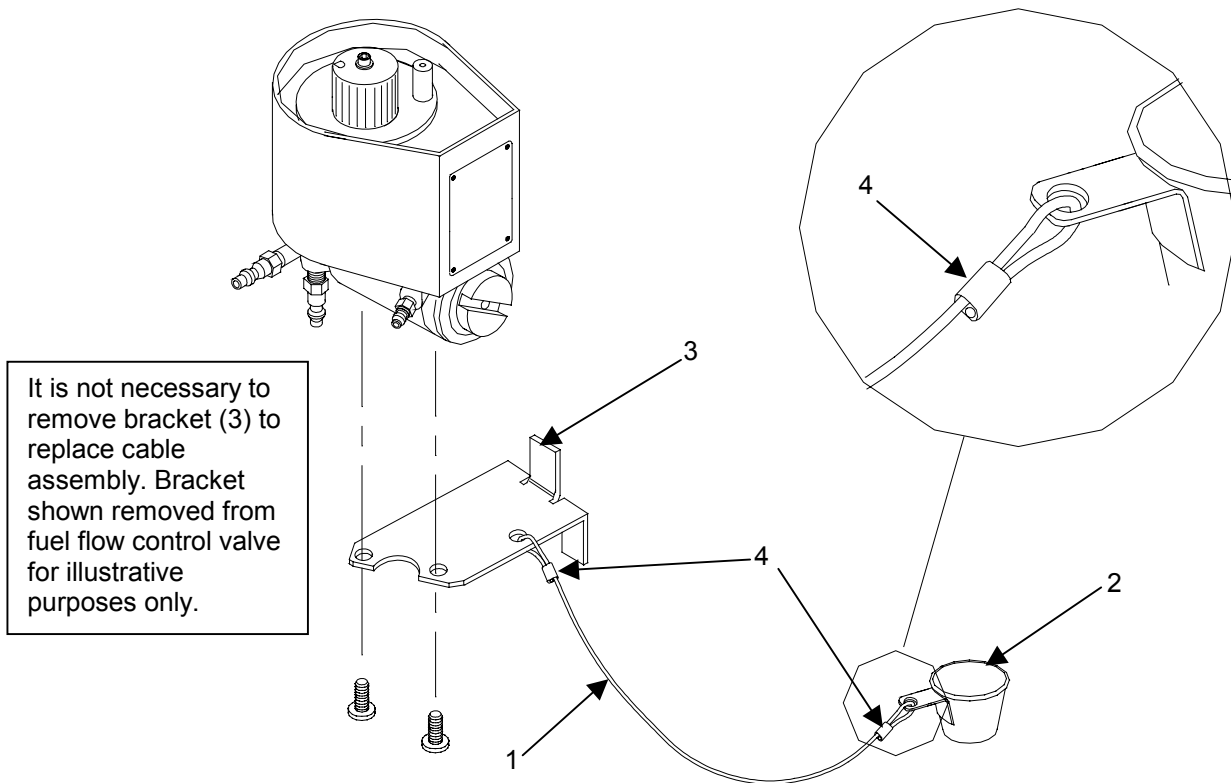

END OF WORK PACKAGE

FUEL FLOW CONTROL VALVE BRACKET

THIS SECTION COVERS:

Replace

INITIAL SETUP

SHA shut-down and cool (WP 0005)
Fuel Flow Control Valve Removed from Heater

Maintenance Level

Unit

Tools and Special Tools

General Mechanic Tool Kit (WP 0025, Table 2, Item 1)

Materials/Parts

REPLACE

Remove two screws (1) securing bracket (2) to fuel flow control valve (3).

Obtain a serviceable bracket (2) and install on fuel flow control valve (3).

Install and tighten two screws (1).

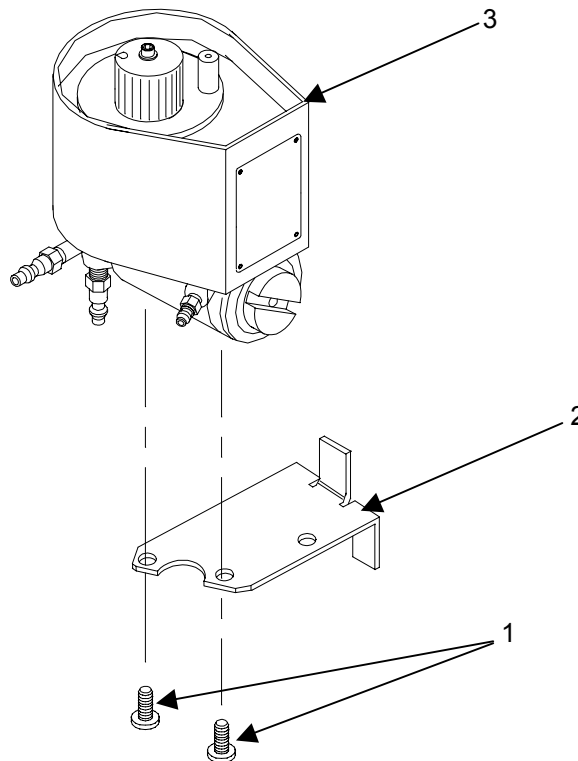

END OF WORK PACKAGE

THIS PAGE INTENTIONALLY LEFT BLANK

BURNER SHELL AND DOWN TUBE ASSEMBLIES**THIS SECTION COVERS:**

Service

INITIAL SETUP

SHA shut-down and cool (WP 0005)
Solid Fuel Grate and Burner Cover Assembly
removed from burner body

Maintenance Level

Unit

Tools and Special Tools

General Mechanic Tool Kit (WP 0025, Table 2, Item 1)

Materials/Parts

Wiping Rags (WP 0046, Table 1, Item 1)

SERVICE

Unlatch/open door assembly (1).

Open lid assembly (2).

Reach into burner shell assembly (3) and pull down tube assembly (4) from up-tube (5) (may need to twist off).

Remove cleaning tool (6) from storage enclosure (7).

Reach into burner shell assembly (3) and insert reaming tool (6) fully into up-tube (5) (may need to twist tool into up-tube).

Twist tool (6) out of up-tube (5) to scrape off residue.

Insert tool (6) and move in and out of the up-tube several times.

Loosened residue will burn off in next use of heater in liquid fuel mode.

Use a wire brush to loosen any heavy deposits of carbon or soot from inside of burner shell assembly (3), and down tube assembly (4).

**CAUTION!**
Heater Malfunction

Do not allow any water to remain in the burner up-tube. This may result in poor operation of the heater next time it is used.

Wash inside of burner shell assembly (3), outside of up-tube (5) and down tube assembly (4), with hot, soapy water. Be careful not to leave water in up-tube. Be sure to wipe out all loose debris in bottom of the burner shell assembly (3).

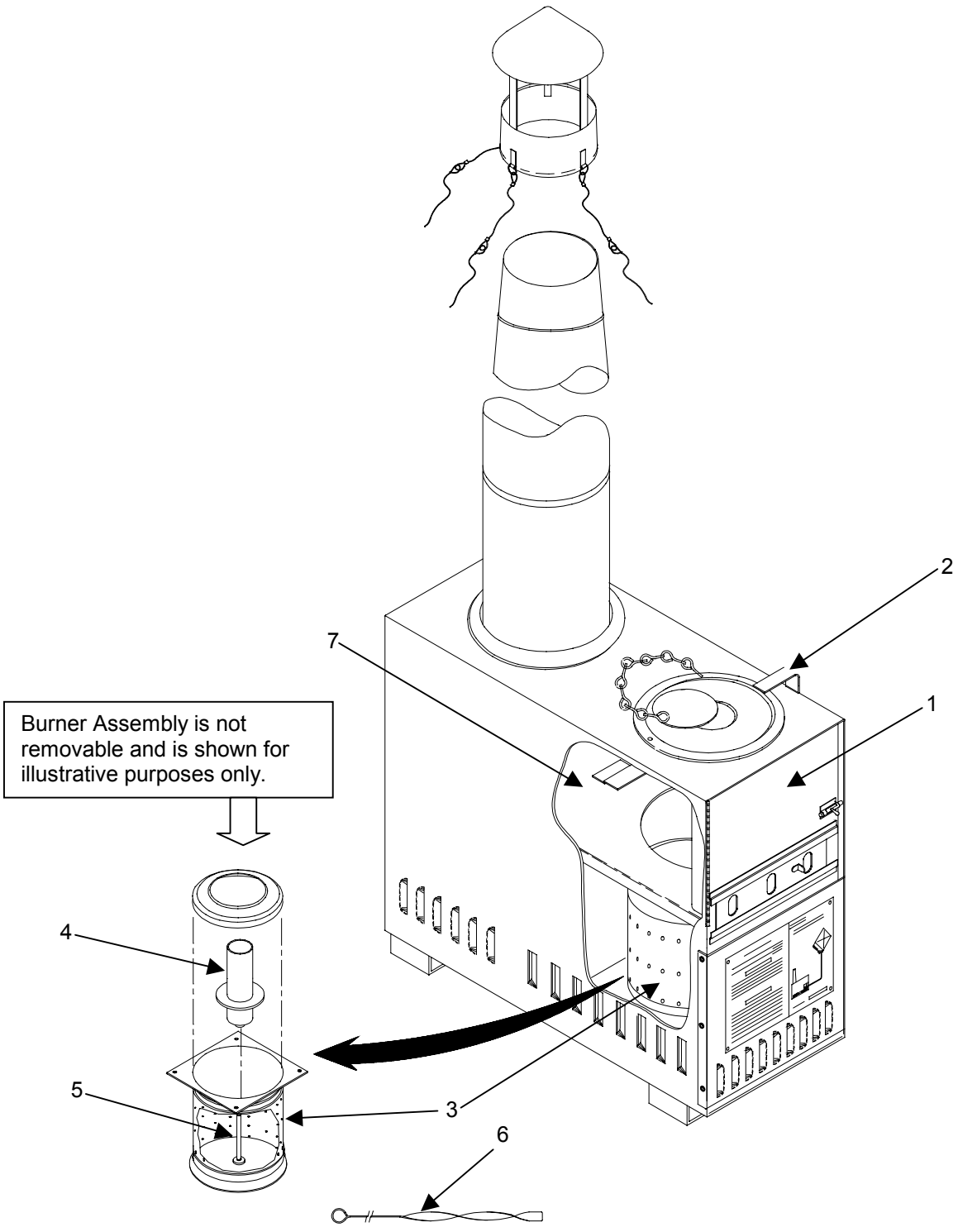

END OF WORK PACKAGE

PREPARATION FOR SHIPMENT OR STORAGE**GENERAL****WARNING!****Two Person Lift**

The SHA weighs approximately 40 pounds (18 kg). Two persons must carry the SHA when lifting or lowering the unit from 3 feet or more. Be sure to lift with legs, not back, to prevent injury.

All Preventive Maintenance Checks and Services IAW PMCS WP 0010 must be complete.

Correct all defects and failures, and apply all Modification Work Orders (MWO's).

Wipe down all metal heater components inside and out with a rag dampened with a light lubricant such as WD-40. Failure to do so will encourage the components to rust.

Wrap small, loose components in packing material. Pack heater into original crate, if available.

Attach equipment securely to vehicle when shipping to another site to prevent damage.

Do not store equipment in damp/wet areas for prolonged periods, as to prevent corrosion and other damage.

END OF WORK PACKAGE

THIS PAGE INTENTIONALLY LEFT BLANK

TM 10-4520-261-12&P

CHAPTER 5
SUPPORTING INFORMATION
FOR
SPACE HEATER ARCTIC

THIS PAGE INTENTIONALLY LEFT BLANK

SCOPE

This section lists all field manuals, forms, technical manuals and miscellaneous publications referenced in this manual.

PAMPHLETS

Functional User=s Manual for the
Army Maintenance Management System (TAMMS)..... DA Pam 738-750

FIELD MANUALS

Basic Cold Weather Manual FM 31-70
First Aid for Soldiers FM 21-11
Decontamination Procedures..... FM 3-5
Mountain Operations FM 90-6
Northern Operations FM 31-71

FORMS

Discrepancy in Shipment Report.....SF 361
Equipment Inspection and Maintenance Worksheet DA Form 2404
Product Quality Deficiency ReportSF 368
Recommended Changes to Equipment Technical Publications DA Form 2028-2
Report of Discrepancy..... SF 364
Report of Packaging and Handling DeficienciesSF 362

TECHNICAL MANUALS

Destruction of Army Material to Prevent Enemy Use TM 750-244-2
Administrative Storage of Equipment TM 740-90-1
Preservation, Packaging, and Packing of Military Supplies and Equipment TM 38-230-2

MISCELLANEOUS PUBLICATIONS

Army Medical Department Expendable/Durable ItemsCTA 8-100
Expendable/Durable Items..... CTA 50-970

THIS PAGE INTENTIONALLY LEFT BLANK

**SPACE HEATER ARCTIC (SHA)
MAINTENANCE ALLOCATION CHART
INTRODUCTION**

0024 00

The Army Maintenance System MAC

This introduction provides a general explanation of all maintenance and repair functions authorized at various maintenance levels under the standard Army Maintenance System concept.

The MAC (immediately following the introduction) designates overall authority and responsibility for the performance of maintenance functions on the identified end item or component. The application of the maintenance functions to the end item or component shall be consistent with the capacities and capabilities of the designated maintenance levels, which are shown on the MAC in column (4) as:

- Unit - includes two subcolumns, C (operator/crew) and O (unit) maintenance
- Direct Support - includes an F subcolumn
- General Support - includes an H subcolumn
- Depot - includes a D subcolumn

The tools and test equipment requirements (immediately following the MAC) list the tools and test equipment (both special tools and common tool sets) required for each maintenance function as referenced from the MAC.

The remarks (immediately following the tools and test equipment requirements) contain supplemental instructions and explanatory notes for a particular maintenance function.

Maintenance Functions

Maintenance functions will be limited to and are defined as follows:

Inspect. To determine the serviceability of an item by comparing its physical, mechanical, and/or electrical characteristics with established standards through examination (e.g., by sight, sound, or feel.)

Test. To verify serviceability by measuring the mechanical, pneumatic, hydraulic, or electrical characteristics of an item and comparing those characteristics with prescribed standards

Service. Operations required periodically to keep an item in proper operating condition, i.e. to clean (includes decontaminate, when required), to preserve, to drain, to paint, or to replenish fuel, lubricants, chemical fluids, or gases.

Adjust. To maintain or regulate, within prescribed limits, by bringing into proper or exact position, or by setting the operating characteristics to specified parameters.

Align. To adjust specified variable elements of an item to bring about optimum performance.

Calibrate. To determine and cause corrections to be made, or to be adjusted on instruments, tests, measuring, and diagnostic equipment used in precision measurement. Consists of comparisons of two instruments, one of which is a certified standard of known accuracy, to detect and adjust any discrepancy in the accuracy of the instrument being compared.

**SPACE HEATER ARCTIC (SHA)
MAINTENANCE ALLOCATION CHART**

0024 00

Remove/Install. To remove and install the same item when required to perform service or other maintenance functions. Install may be the act of emplacing, seating, or fixing into position a spare, repair part, or module (component or assembly) in a manner to allow the proper function of equipment or system.

Replace. To remove an unserviceable item and install a serviceable counterpart in its place. A Replace is authorized by the MAC and is shown as the 3rd position code of the SMR code.

Repair. The application of maintenance services, including fault location/troubleshooting, removal/installation, and disassembly/assembly procedures, and maintenance actions to identify troubles, and restore serviceability to an item by correcting specific damage, fault, malfunction, or failure in a part, subassembly, module (component or assembly), end item, or system.

**NOTE!**

The following definitions are applicable to the "repair" maintenance function:

Services - Inspect, test, service, adjust, align, calibrate, and/or replace.

Fault location/troubleshooting-The process of investigating and detecting the cause of equipment malfunctioning; the act of isolating a fault within a system or Unit Under Test (UUT).

Disassembly/assembly-The step by step breakdown (taking apart) of a spare/functional group coded item to the level of its least component, that is assigned an SMR code for the level of maintenance under consideration (i.e. identified as maintenance significant).

Actions-Welding, grinding, riveting, straightening, facing, machining, and or resurfacing.

Overhaul. That maintenance effort (service/action) prescribed to restore an item to a completely serviceable/operational condition as required by maintenance standards in appropriate technical publications (i.e., DMWR). Overhaul is normally the highest degree of maintenance performed by the Army. Overhaul does not normally return an item to like new condition.

Rebuild. Consists of those services/actions necessary for the restoration of unserviceable equipment to a like new condition in accordance with original manufacturing standards. Rebuild is the highest degree of material maintenance applied to Army equipment. The rebuild operation includes the act of returning to zero those age measurements (hours/miles, etc.) considered in classifying Army equipment/components.

Explanation of Columns in the MAC

Column 1, Group Number. Column 1 lists functional group code numbers, the purpose of which is to identify maintenance significant components, assemblies, subassemblies, and modules with the next higher assembly. End item group numbers are A00.

Column 2, Component/Assembly. Column 2 contains the names of components, assemblies, subassemblies, and modules for which maintenance is authorized.

**SPACE HEATER ARCTIC (SHA)
MAINTENANCE ALLOCATION CHART**

0024 00

Column 3, Maintenance Function. Column 3 lists the functions to be performed on the item listed in Column 2. (For detailed explanation, refer to the previous section entitled "Maintenance Functions")

Column 4, Maintenance Level. Column 4 specifies, by the listing of a work time figure (expressed as man-hours shown as whole hours or decimals) in the appropriate subcolumn(s), the level of maintenance authorized to perform the function listed in Column (3). This figure represents the active time required to perform that maintenance function at the indicated level of maintenance. If the number or the complexity of the tasks within the listed maintenance function vary at different maintenance levels, appropriate work time figures will be shown for each level. The work time figure represents the average time required to restore an item (assembly, subassembly, component, module, end item, or system) to a serviceable condition under typical field operating conditions. This time includes item preparation (including any necessary disassembly/assembly time), troubleshooting/fault location time, and quality assurance/quality control time in addition to the time required to perform the specific tasks identified for the maintenance functions authorized in the maintenance allocation chart. The system designations for the various maintenance levels are shown below:

- C Operator or crew
- F Direct Support Maintenance
- D Depot Maintenance
- O Unit Maintenance
- H General Support Maintenance

Column 5, Tools and Equipment. Column 5 specifies, by code, those common tool sets (not individual tools) common TMDE, and special tools, special TMDE, and support equipment required to perform the designated function.

Column 6, Remarks. This column, when applicable, contains a letter code, in alphabetic order, which is keyed to the remarks contained in Table 3.

Explanation of Columns in the Tools and Test Equipment Requirements

Column (1) - Tool or Test Equipment Reference Code. The tool or test equipment reference code correlates with a code used in column (5) of the MAC.

Column (2) - Maintenance Level. The lowest level of maintenance authorized to use the tool or test equipment.

Column (3) - Nomenclature. Name or identification of tool or test equipment.

Column (4) - National Stock Number (NSN). The NSN of the tool or test equipment.

Column (5) - Tool Number. The manufacturer's part number, model number, or type number.

Explanation of Columns in Remarks

Column (1) - Remarks Code. The code recorded in Column (6) of the MAC.

Column (2) - Remarks. This column lists information pertinent to the maintenance function being performed as indicated in the MAC.

**SPACE HEATER ARCTIC (SHA)
MAINTENANCE ALLOCATION CHART**

Table 1. MAC for SPACE HEATER ARCTIC

(1) Group Number	(2) Component/Assembly	(3) Maintenance Function	(4) Maintenance Level					(5) Tools & Equip.	(6) Remarks
			Unit		Direct Support	General Support	Depot		
			C	O	F	H	D		
00	Space Heater Arctic	Inspect	0.2						
		Service Repair		0.5				1	
01	Stack Cap Assembly	Inspect	0.1						
		Service Repair		0.5				1	
0101	Rope, Wire	Inspect	0.1						
		Replace		0.5				2	
0102	Lines, Tent	Inspect	0.1						
		Replace		0.5				1	
02	Stack Assembly	Inspect	0.1						
		Service Repair		0.5				1	
03	Burner Body Assembly	Inspect	0.1						
		Service Repair		0.5				1	
0301	Hose, Fuel Control	Inspect	0.1						
		Replace		0.5				1	
04	Lid Assembly	Inspect	0.1						
		Replace		0.5					
05	Fuel Flow Control Assy	Inspect	0.1						
		Service Repair		0.5				1	
0501	Bracket	Inspect	0.2						
		Replace		0.3				1	
0502	Cup/Cable Assembly	Inspect	0.2						
		Repair		0.5				2	
06	Solid Fuel Gate	Inspect	0.2						
		Replace		0.2				2	

**SPACE HEATER ARCTIC (SHA)
MAINTENANCE ALLOCATION CHART**

Table 1. MAC for SPACE HEATER ARCTIC – Continued

07	Rear Door	Inspect Repair Replace	0.2	0.1 0.5				1	
08	Burner Cover	Inspect Repair Replace	0.2	0.1 0.1				1 1	
09	Down-Tube Assembly	Inspect Service Replace	0.1	0.5 0.5				1	
10	Burner Reamer Tool	Inspect Replace	0.2	0.1					
11	Fuel Hose Kit	Inspect Repair Replace	0.1	1.0 1.0				1 1	
12	Gravity Feed Adaptor	Inspect Replace	0.1	0.5					

Table 2. Tools and Test Equipment for Space Heater Arctic

Tool or Test Equipment Ref Code	Maintenance Level	Nomenclature	National Stock Number	Tool Number
1	O	Tool Kit, General Mechanic's	5180-00-177-7033	SC 5180-90-CL-N26
2	O	Swaging Tool		

Table 3. Remarks for SHA

REMARKS CODE	REMARKS
	N/A

THIS PAGE INTENTIONALLY LEFT BLANK

**SPACE HEATER ARCTIC (SHA)
REPAIR PARTS AND SPECIAL TOOLS LIST (RPSTL)**

SCOPE

This RPSTL lists and authorizes spare and repair parts; special tools; special tests, measurement and diagnostic equipment (TMDE); and other special support equipment required for performance of unit and direct support maintenance of the SHA. It authorizes the requisitioning, issue, and disposition of spares, repair parts, and special tools as indicated by the source, maintenance, and recoverability (SMR) codes.

GENERAL

In addition to this section, this RPSTL is divided into the following additional sections:

Repair Parts Sections. These sections contain lists of spares and repair parts authorized by this RPSTL for use in the performance of maintenance. These sections also include parts that must be removed for replacement of the authorized parts. Parts lists are composed of functional groups in ascending alphanumeric sequence, with the parts in each group listed in ascending figure and item number sequence. Hardware is listed with the components used. Bulk materials are listed by item name in FIG. BULK at the end of the sections. Repair parts kits are listed separately in their own functional group and section. Repair parts for repairable special tools are also listed in a separate section. Items listed are shown on the associated illustrations.

Special Tools List Sections. Sections containing lists of special tools, special TMDE, and special support equipment authorized by this RPSTL (as indicated by Basis of Issue (BOI) information in the DESCRIPTION AND USABLE ON CODE (UOC) column). Tools that are components of common tool sets and/or Class VII are not listed.

Cross-Reference Index Sections. There are two cross-reference indexes in this RPSTL; the National Stock Number (NSN) Index, and the Part Number Index. The NSN index refers you to the figure and the item number. The part number index also refers you to the figure and item number.

EXPLANATION OF COLUMNS IN THE RPSTL

ITEM NO. (Column (1)). Indicates the number used to identify items called out in the illustration.

SMR Code (Column (2)). The Source, maintenance, and recoverability (SMR) code is a 5-position code containing supply / requisitioning information, maintenance category authorization criteria and disposition instruction, as shown in the following breakout.

Source Code	Maintenance Code	Recoverability Code
X X	X	X
1st two positions:	3rd Position:	5th Position:
How you get an item	Who can install replace or use the item	Who determines disposition action on an item
	Who can do complete repair* on the item	

*Complete Repair: Maintenance capacity, capability, and authority to perform all corrective maintenance tasks of the ARepair≡ function in a use/user environment in order to restore serviceability to a failed item.

**SPACE HEATER ARCTIC (SHA)
REPAIR PARTS AND SPECIAL TOOLS LIST (RPSTL)**

Source Code. The source code, tells you how to get an item needed for maintenance, repair, or overhaul of an end item/equipment. Explanation of source codes follows.

Source Code	Explanation
PA	Stock items; use the applicable NSN to request/requisition items with these source codes. They are authorized to the category indicated by the code entered in the third position of the SMR code.
PB	
PC**	
PD	
PE	
PF**	
PG	NOTE: Items coded PC are subject to deterioration.
KB	Items with these codes are not to be requested/requisitioned individually. They are part of a kit which is authorized to the maintenance category indicated in the 3rd position of the SMR code. The complete kit must be requisitioned and applied.
KD	
KF	
MO - Made at unit/AVUM Level	Items with these codes are not to be requested/requisitioned individually. They must be made from bulk material that is identified by the part number in the DESCRIPTION AND USABLE ON CODE (UOC) column and listed in the Bulk Material group of the repair parts list in this RPSTL. If the item is authorized to you by the 3rd position code of the SMR code, but the source code indicates it is made at a higher level, order the item from the higher level of maintenance.
MF- Made at DS/AVIM Level	
MH - Made at GS Level)	
ML - Made at Specialized Repair Act. (SRA)	
MD - Made at Depot	
AO - Assembled by Unit/AVUM Level	Items with these codes are not to be requested/requisitioned individually. The parts that make up the assembled item must be requisitioned or fabricated and assembled at the level of maintenance indicated by the source code. If the third position code of the SMR code authorizes you to replace the item, but the source code indicates the item is assembled at a higher level.
AF - Assembled by DS/AVIM Level	
AH - Assembled by GS level	
AL - Assembled by SRA order the item from the higher level of maintenance.	
AD - Assembled by Depot	
XA	Do not requisition an "XA" coded item. Order its next higher assembly. (Also, refer to the NOTE below.)
XB	If an "XB" item is not available from salvage, order it using the CAGEC and part number given.
XC	Installation drawing, diagram, instruction sheet, field service drawing, that is identified by manufacturer's part number.
XD	Item is not stocked. Order an "XD" coded item through normal supply channels using the CAGEC and part number given, if no NSN is available.



NOTE!

Cannibalization or controlled exchange, when authorized, may be used as a source of supply for items with the above source codes, except for those source coded "XA" or those aircraft support items restricted by requirements of AR 750-1.

Maintenance Code. Maintenance codes tell you the level(s) of maintenance authorized to use and repair support items. The maintenance codes are entered in the third and fourth positions of the SMR Code as follows:

Third Position. The maintenance code entered in the third position tells you the lowest maintenance level authorized to remove, replace, and use the support item. The maintenance code entered in the third position will indicate authorization to one of the following levels of maintenance.

Maintenance Code	Application/Explanation
C	Crew or operator maintenance done within unit/AVUM maintenance.
O	Unit level/AVUM maintenance can remove, replace, and use the item.
F	Direct support/AVIM maintenance can remove, replace, and use the item.
H	General support maintenance can remove, replace, and use the item.
L	Specialized repair activity can remove, replace, and use the item.
D	Depot level can remove, replace, and use the item.

Fourth Position. The maintenance code entered in the fourth position tells whether or not the item is to be repaired and identifies the lowest maintenance level with the capability to do complete repair (i.e., perform all authorized repair functions).



NOTE!

Some limited repair may be done on the item at a lower level of maintenance, if authorized by the Maintenance Allocation Chart (MAC) and SMR codes.

Maintenance Code	Application/Explanation
O	Unit/AVUM is the lowest level that can do complete repair of the item.
F	Direct support/AVIM is the lowest level that can do complete repair of the item.
H	General support is the lowest level that can do complete repair of the item.
L	Specialized repair activity (designate the specialized repair activity) is the lowest level that can do complete repair of the item.
D	Depot is the lowest level that can do complete repair of the item.
Z	Nonrepairable. No repair is authorized.

**SPACE HEATER ARCTIC (SHA)
REPAIR PARTS AND SPECIAL TOOLS LIST (RPSTL)**

B No repair is authorized. (No parts or special tools are authorized for the maintenance of a "B" coded item.) However, the item may be reconditioned by adjusting, lubricating, etc., at the user level.

Recoverability Code. Recoverability codes are assigned to items to indicate the disposition action on unserviceable items. The recoverability code is entered in the fifth position of the SMR Code as follows:

Code	Application/Explanation
Z	Nonrepairable item. When unserviceable, condemn and dispose of the item at the level of maintenance shown in 3rd position of SMR Code.
O	Repairable item. When uneconomically repairable, condemn and dispose of the item at organizational or aviation unit level.
F	Repairable item. When uneconomically repairable, condemn and dispose of the item at the direct support or aviation intermediate level.
H	Repairable item. When uneconomically repairable, condemn and dispose of the item at the general support level.
D	Repairable item. When beyond lower level repair capability, return to depot. Condemnation and disposal of item not authorized below depot level.
L	Repairable item. Condemnation and disposal not authorized below Specialized Repair Activity (SRA).
A	Item requires special handling or condemnation procedures because of specific reasons (e.g., precious metal content, high dollar value, critical material, or hazardous material). Refer to appropriate manuals/ directives for specific instructions.

NATIONAL STOCK NUMBER (NSN) (Column (3)). The NSN for the item is listed in this column.

CAGEC (Column (4)). The Commercial and Government Entity Code (CAGEC) is a 5-digit numeric code which is used to identify the manufacturer, distributor, or Government agency/activity that supplies the item.

PART NUMBER (Column (5)). Indicates the primary number used by the manufacture, (individual company, firm, corporation, or Government activity), which controls the design and characteristics of the item by means of its engineering drawings, specifications, standards, and inspection requirements to identify an item or range of items.



NOTE!

When an item with an assigned NSN is requisitioned, the part number for the item received may be different than the part number of the item being replaced.

DESCRIPTION AND USABLE ON CODE (UOC) (Column (6)). This column includes the following information:

The federal item name and, when required, a minimum description to identify the item.

Part numbers of bulk materials are referenced in this column in the line entry to be manufactured/fabricated.

Hardness Critical Item (HCI). A support item that provides the equipment with special protection from electromagnetic pulse (EMP) damage during a nuclear attack.

The statement "END of FIGURE" appears just below the last item description in Column (5) for a given figure in both the repair parts list and special tools list.

QTY (Column (8)). The QTY (quantity per figure) column indicates the quantity of the item used in the breakout shown on the illustration/figure, which is prepared for a functional group, subfunctional group, or an assembly. A "V" appearing in this column instead of quantity indicates that the quantity is a variable with each application.

EXPLANATION OF CROSS REFERENCE INDEX FORMAT AND COLUMNS

National Stock Number (NSN) Index

STOCK NUMBER Column. This column lists the NSN in national item identification number (NIIN) sequence. The NIIN consists of the last nine digits of the NSN, i.e.

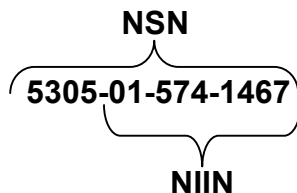

When using this column to locate an item, ignore the first four digits of the NSN. Use the complete NSN (13 digits) when requisitioning by stock number.

FIG. COLUMN. This column lists the number of the figure where the item is identified/located. The figures are in numerical order in Section II and Section III.

ITEM COLUMN. The Item number identifies the item associated with the figure listed in the adjacent FIG. Column. This item is also identified by the NSN listed on the same line.

PART NUMBER INDEX. Part numbers in this index are listed by part number in ascending alphanumeric sequence (i.e. vertical arrangement of letter and number combination which place the first letter or digit of each group in order A through Z, followed by the numbers 0 through 9, and each following letter or digit in like order).

CAGEC COLUMN. The Commercial and Government Entity Code (CAGEC) is a 5-digit numeric code used to identify the manufacturer, distributor, or Government agency/activity that supplies the item.

PART NUMBER COLUMN. Indicates the primary number used by the manufacturer (individual, firm, corporation, or government activity), which controls the design and characteristics of the item by means of its engineering drawings, specifications, standards and inspection requirements to identify an item or range of items.

STOCK NUMBER COLUMN. This column lists the NSN for the associated part number and manufacturer identified in the PART NUMBER and CAGEC columns to the left.

FIG. COLUMN. This column lists the number of the figure where the item is identified/located in the repair

**SPACE HEATER ARCTIC (SHA)
REPAIR PARTS AND SPECIAL TOOLS LIST (RPSTL)**

parts list and special tools list.

ITEM COLUMN. The item number is that number assigned to the item as it appears in the figure referenced in adjacent figure number column.

REFERENCE DESIGNATOR Column. Indicates the reference designator assigned to the item.

FIG. COLUMN. This column lists the number of the figure where the item is identified/located in the repair parts list and special tools list.

ITEM COLUMN. The item number is that number assigned to the item as it appears in the figure referenced in the adjacent figure number column.

STOCK NUMBER COLUMN. This column lists the NSN for the item.

CAGEC COLUMN. The Commercial and Government Entity Code (CAGEC) is a 5-digit numeric code used to identify the manufacturer, distributor, or Government agency/activity that supplies the item.

PART NUMBER COLUMN. Indicates the primary number used by the manufacturer (individual, firm, corporation, or Government activity), which controls the design and characteristics of the item by means of its engineering drawings, specifications, standards, and inspection requirements to identify an item or range of items.

SPECIAL INFORMATION.

USABLE ON CODE (UOC). The useable on code appears in the lower left corner of the Description Column heading. Useable on codes are shown as AUOC≅ in the Description Column (justified left) on the first line under the applicable item description/nomenclature. Uncoded items are applicable to all models. Identification of the usable on codes used in this RPSTL are:

There are no Usable On Codes applicable to the Space Heater Arctic

FABRICATION INSTRUCTIONS. Bulk materials required to manufacture items are listed in the Bulk Material Functional Group of this RPSTL. Part numbers for bulk materials are also referenced in the description column of the line entry for the item to be manufactured/fabricated. Detailed fabrication instructions for items source coded to be manufactured or fabricated are found in TB 10-4500-200-13.

INDEX NUMBER. Items that have the word BULK in the figure column will have an index number shown in the item number column. This index number is a cross-reference between the National Stock Number/Part Number Index and the bulk material list in Section II.

ASSOCIATED PUBLICATIONS. The publications listed below pertain to the Space Heater Arctic and its components.

PUBLICATION	SHORT TITLE
TM 10-4520-261-12&P	Space Heater Arctic (SHA)

HOW TO LOCATE REPAIR PARTS.

When National Stock Numbers or Part Numbers are NOT known. First, using the table of contents, determine the assembly or subassembly group to which the item belongs. This is necessary since figures are prepared for assembly groups and subassembly groups, and listings are divided into the same groups.

Second, find the figure covering the assembly group or subassembly group to which the item belongs.

Third, identify the item on the figure and note the number(s).

Fourth, look in the repair parts list for the figure and item numbers. The NSNs and part numbers are on the same line as the associated item numbers.

When National Stock Number or Part Number IS known. First, if you have the NSN, look in the STOCK NUMBER column of the NSN index. The NSN is arranged in NIIN sequence. Note the figure and item number next to the NSN.

Second, turn to the figure and locate the item number. Verify that the item is the one you are looking for.

When Part Number is known. First, if you have the P/N and not the NSN, look in the PART NUMBER column of the P/N index. Identify the figure and item number.

Second, look up the item on the figure in the applicable repair parts list.

THIS PAGE INTENTIONALLY LEFT BLANK

THIS PAGE INTENTIONALLY LEFT BLANK

1
INCLUDES 2 THRU 4

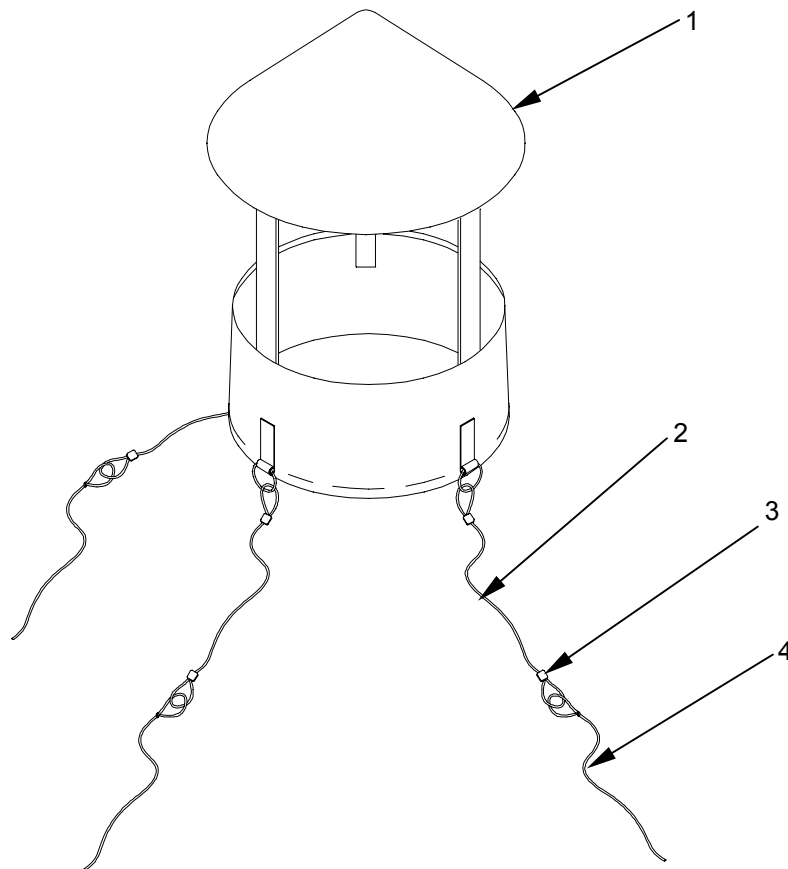

Figure 1. Group 01 Stack Cap Assembly
0026 00-(1 Blank)/2

TM 10-4520-261-12&P

GROUP 01 STACK CAP ASSEMBLY
PARTS LIST - continued

0026 00

(1) ITEM NO.	(2) SMR CODE	(3) NSN	(4) CAGEC	(5) PART NUMBER	(6) DESCRIPTION AND USABLE ON CODE (UOC)	(7) QTY
					GROUP 01 STACK CAP ASSEMBLY	
					FIG. 1 STACK CAP ASSEMBLY	
1	PAOOO	4520-01-469-5534	92878		STACK CAP ASSY	1
2	XDOZZ		92878	MIL-W-83420	. ROPE, WIRE, TYPE I, 7 X 7 X 7/32 IN	v
3	XDOZZ		92878	171218	. TENT LINE POLY PACK	1
4	XDOZZ		92878	MS51844-83	. SLEEVE, SWAGING	3
					END OF FIGURE	

THIS PAGE INTENTIONALLY LEFT BLANK

THIS PAGE INTENTIONALLY LEFT BLANK

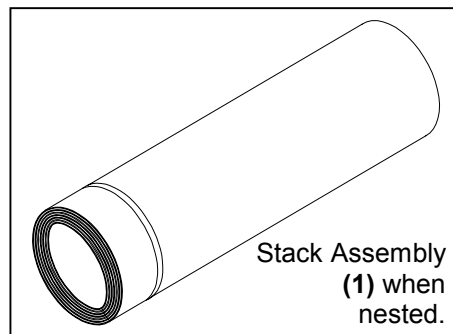
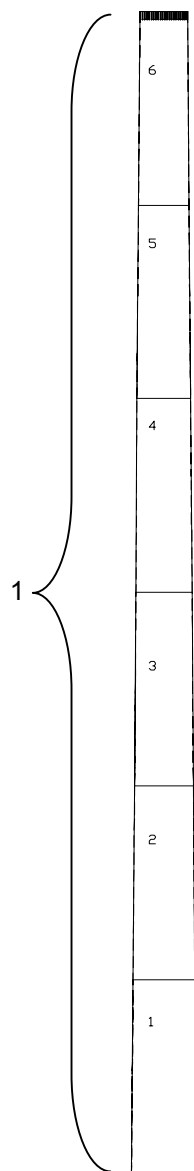

Figure 2. Group 02 Stack Assembly

**GROUP 02 STACK ASSEMBLY
PARTS LIST - continued**

0027 00

(1) ITEM NO.	(2) SMR CODE	(3) NSN	(4) CAGEC	(5) PART NUMBER	(6) DESCRIPTION AND USABLE ON CODE (UOC)	(7) QTY
					GROUP 02 STACK ASSEMBLY	
					FIG. 2 STACK ASSEMBLY	
1	PAOZZ	4520-01-469-5545	92878	106357	STACK, EXHAUST NESTABLE	1
					END OF FIGURE	

THIS PAGE INTENTIONALLY LEFT BLANK

THIS PAGE INTENTIONALLY LEFT BLANK

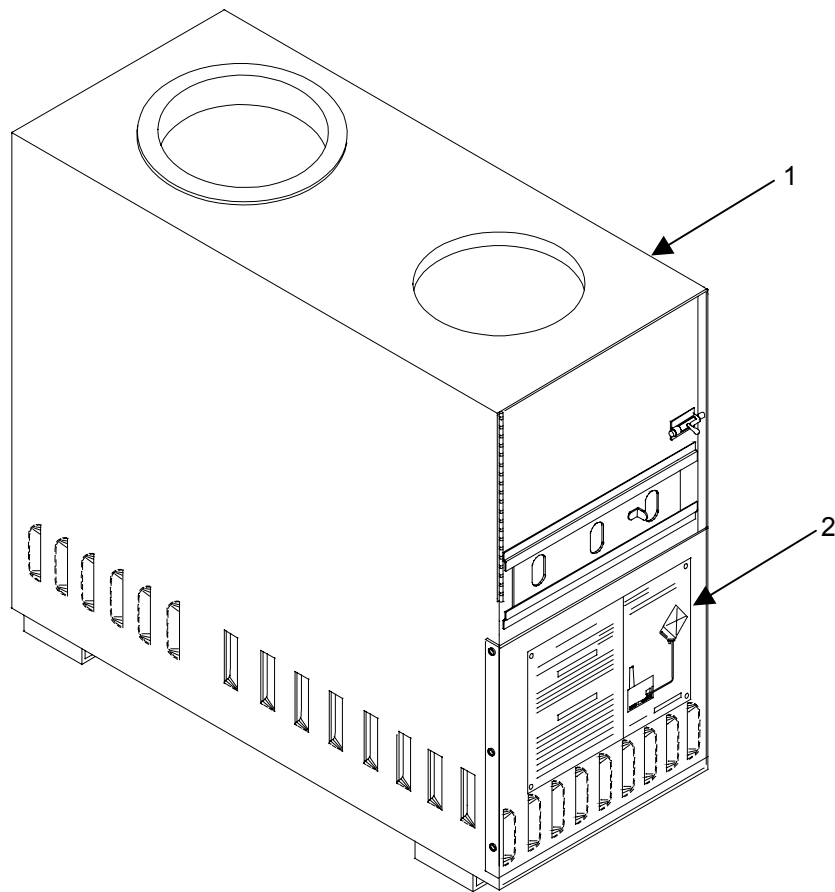

Figure 3. Group 03 Heater Body Assembly

TM 10-4520-261-12&P

**GROUP 03 HEATER BODY ASSEMBLY
PARTS LIST - continued**

0028 00

(1) ITEM NO.	(2) SMR CODE	(3) NSN	(4) CAGEC	(5) PART NUMBER	(6) DESCRIPTION AND USABLE ON CODE (UOC)	(7) QTY
					GROUP 03 HEATER BODY ASSEMBLY	
					FIG. 3 HEATER BODY ASSEMBLY	
1	PAOOO	4520-01-469-5551	92878	106342	HEATER WELDMENT ASSY	1
2	PAOZZ	4520-01-469-5779	92878	106332	PLATE, IDENTIF.	1
					END OF FIGURE	

THIS PAGE INTENTIONALLY LEFT BLANK

THIS PAGE INTENTIONALLY LEFT BLANK

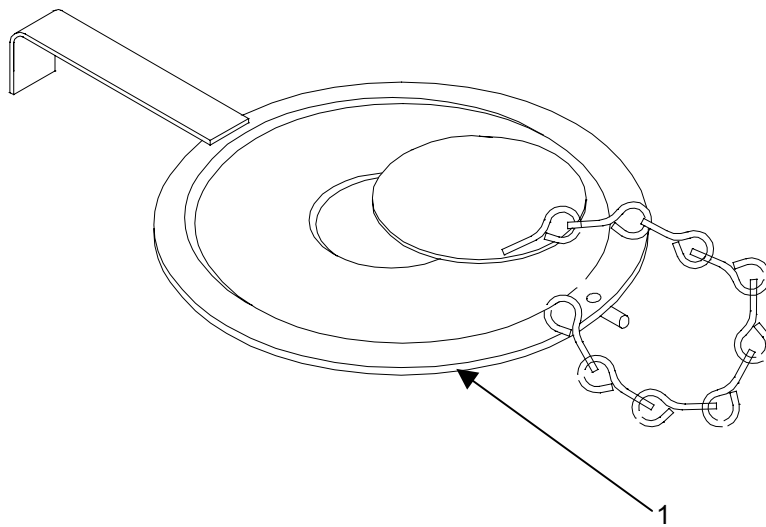

Figure 4. Group 04 Lid Assembly

**GROUP 04 LID ASSEMBLY
PARTS LIST - continued**

0029 00

(1) ITEM NO.	(2) SMR CODE	(3) NSN	(4) CAGEC	(5) PART NUMBER	(6) DESCRIPTION AND USABLE ON CODE (UOC)	(7) QTY
					GROUP 04 LID ASSEMBLY	
					FIG. 4 LID ASSEMBLY	
1	PAOZZ	4520-01-469-5561	92878	106353	LID ASSEMBLY	1
					END OF FIGURE	

THIS PAGE INTENTIONALLY LEFT BLANK

THIS PAGE INTENTIONALLY LEFT BLANK

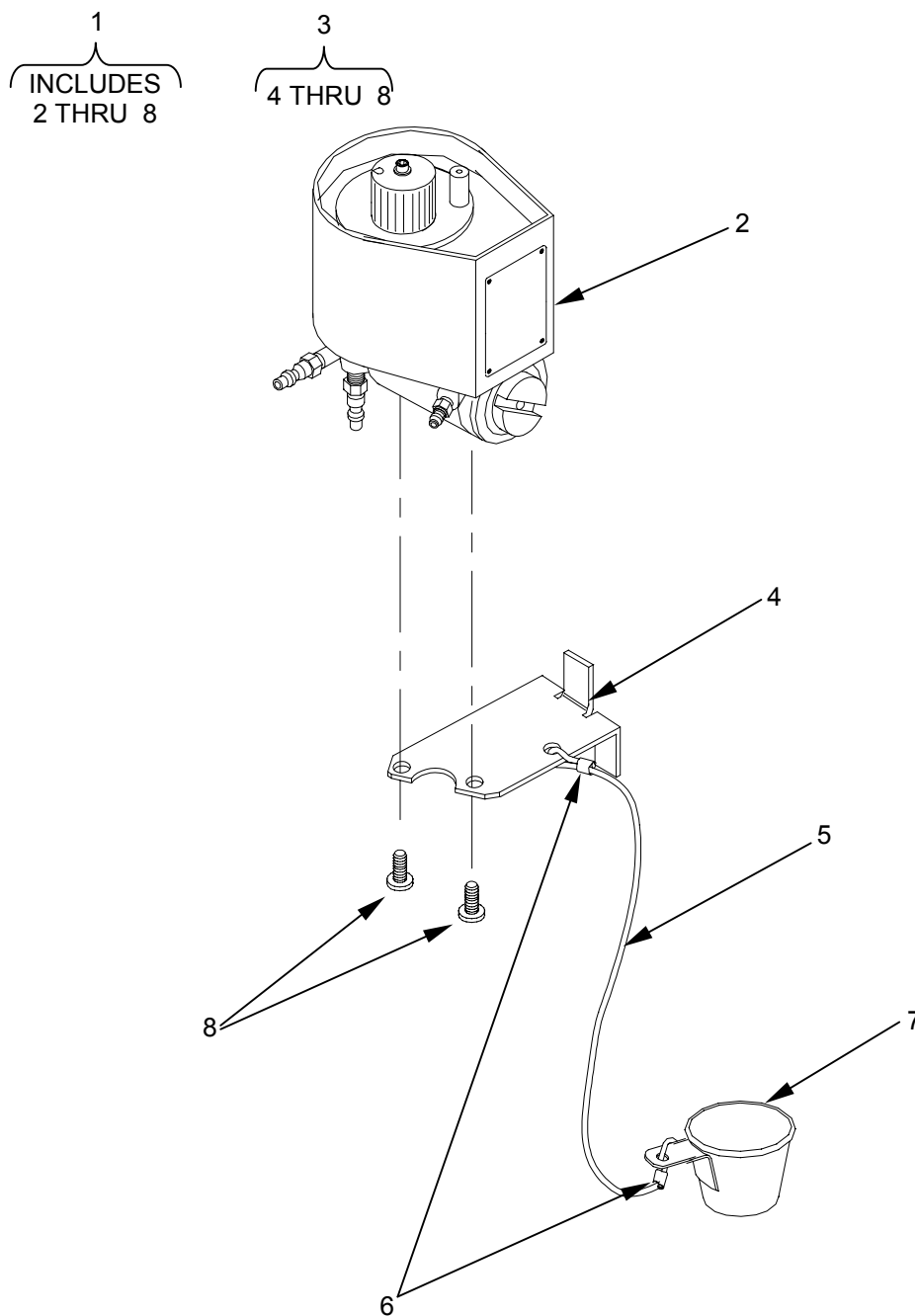

Figure 5. Group 05 Fuel Flow Control Assembly

TM 10-4520-261-12&P

**GROUP 05 FUEL FLOW CONTROL ASSEMBLY
PARTS LIST - continued**

0030 00

(1) ITEM NO.	(2) SMR CODE	(3) NSN	(4) CAGEC	(5) PART NUMBER	(6) DESCRIPTION AND USABLE ON CODE (UOC)	(7) QTY
					GROUP 05 FUEL CONTROL VALVE ASSEMBLY	
					FIG. 5 FUEL CONTROL VALVE ASSEMBLY	
1	PAOZZ	4520-01-466-0409	92878	106366	ASSEMBLY, FUEL CONTROL VALVE W/ CUP/CABLE/BRACKET	1
2	PAOZZ	4520-01-469-5567	92878	106354	. FUEL CONTROL VALVE ASSY	1
3	PAOZZ	4520-01-469-5576	92878	106363	. CUP/CABLE/BRACKET ASSEMBLY	1
4	PAOZZ	4520-01-469-5571	92878	106281	. . BRACKET, VALVE MOUNTING	1
5	XDOZZ		92878	MIL-W-83420	. . WIRE ROPE 7X7 3/32"	AR
6	XDOZZ		92878	MS51844-83	. . SLEEVE, SWAGING	2
7	XDOZZ		92878	106362	. . CUP, 2 OZ. ALUMINUM	1
8	XDOZZ		92878	3050	. . SCREW SEMS 1/4-20 X 3/8	2
					END OF FIGURE	

THIS PAGE INTENTIONALLY LEFT BLANK

THIS PAGE INTENTIONALLY LEFT BLANK

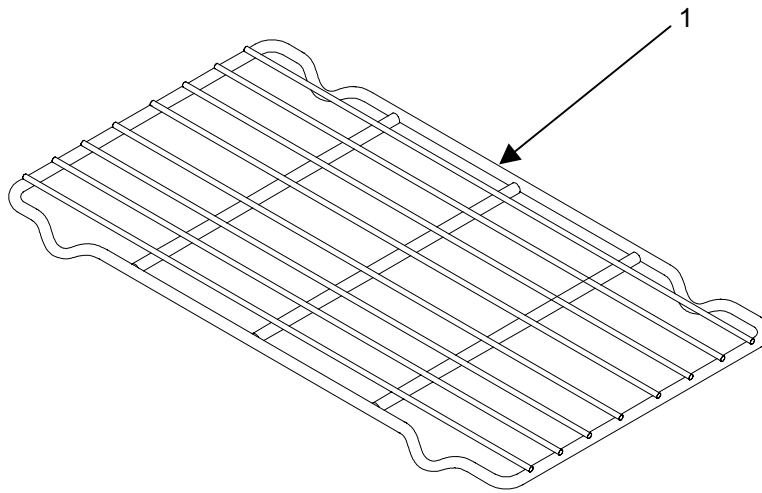

Figure 6. Group 06 Solid Fuel Grate

**GROUP 06 SOLID FUEL GRATE
PARTS LIST - continued**

0031 00

(1) ITEM NO.	(2) SMR CODE	(3) NSN	(4) CAGEC	(5) PART NUMBER	(6) DESCRIPTION AND USABLE ON CODE (UOC)	(7) QTY
					GROUP 06 SOLID FUEL GRATE	
					FIG. 6 SOLID FUEL GRATE	
1	PAOZZ	4520-01-469-5578	92878	106358	WIRE RACK ASSY	1
					END OF FIGURE	

THIS PAGE INTENTIONALLY LEFT BLANK

THIS PAGE INTENTIONALLY LEFT BLANK

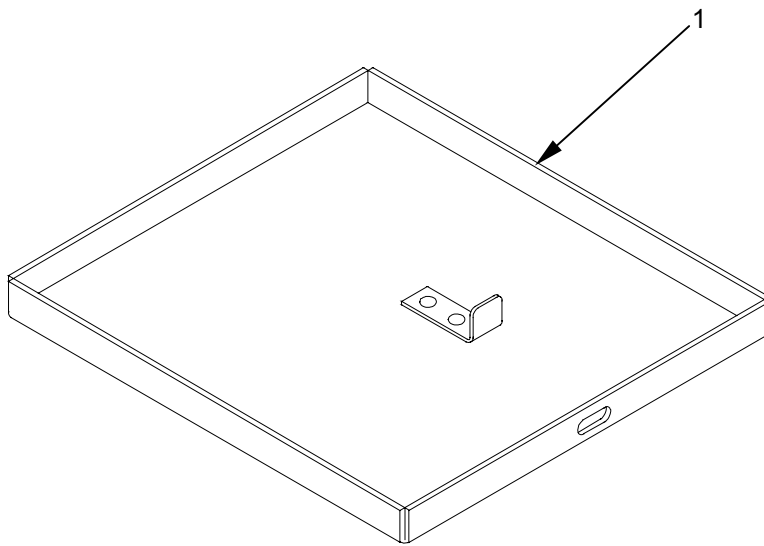

Figure 7. Group 07 Rear Door
0032 00-(1 Blank)/2

**GROUP 07 REAR DOOR
PARTS LIST - continued**

0032 00

(1) ITEM NO.	(2) SMR CODE	(3) NSN	(4) CAGEC	(5) PART NUMBER	(6) DESCRIPTION AND USABLE ON CODE (UOC)	(7) QTY
					GROUP 07 REAR DOOR	
					FIG. 7 REAR DOOR	
1	PAOZZ	4520-01-469-5585	92878	106331	DOOR, STORAGE	1
					END OF FIGURE	

THIS PAGE INTENTIONALLY LEFT BLANK

THIS PAGE INTENTIONALLY LEFT BLANK

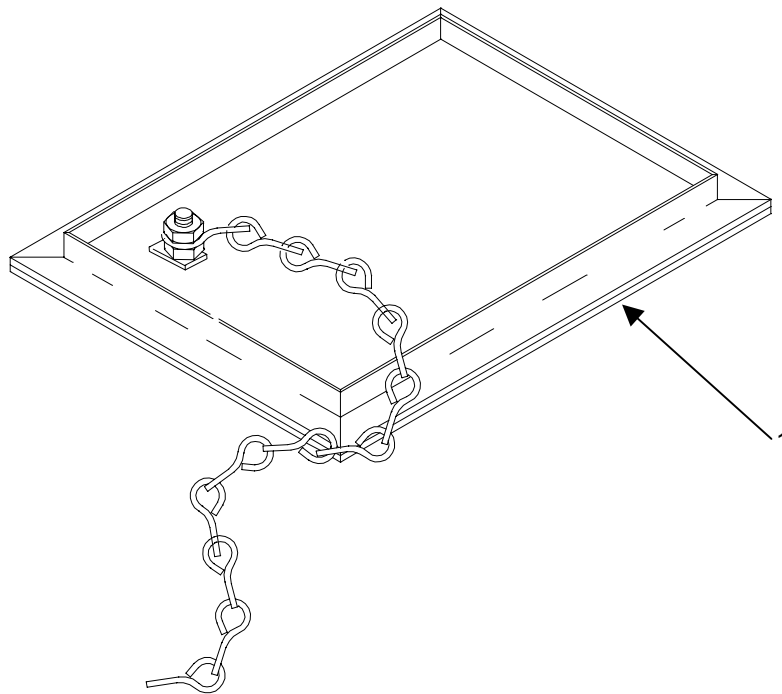

Figure 8. Group 08 Burner Cover

**GROUP 08 BURNER COVER
PARTS LIST - continued**

0033 00

(1) ITEM NO.	(2) SMR CODE	(3) NSN	(4) CAGEC	(5) PART NUMBER	(6) DESCRIPTION AND USABLE ON CODE (UOC)	(7) QTY
					GROUP 08 BURNER COVER	
					FIG. 8 BURNER COVER	
1	PAOZZ	4520-01-469-5743	92878	106261	ASSEMBLY, COVER BURNER	1
					END OF FIGURE	

THIS PAGE INTENTIONALLY LEFT BLANK

THIS PAGE INTENTIONALLY LEFT BLANK

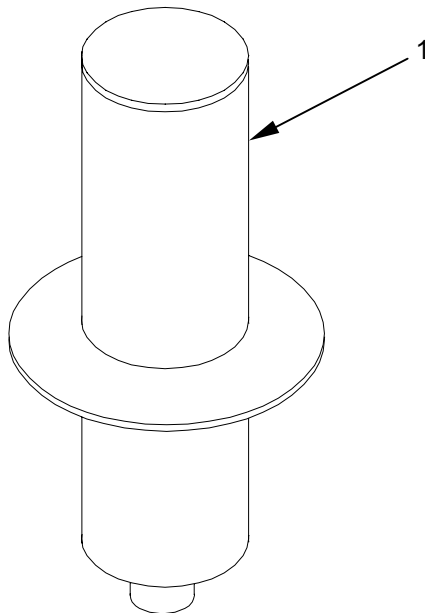

Figure 9. Group 09 Down Tube Assembly

**GROUP 09 DOWN TUBE ASSEMBLY
PARTS LIST - continued**

0034 00

(1) ITEM NO.	(2) SMR CODE	(3) NSN	(4) CAGEC	(5) PART NUMBER	(6) DESCRIPTION AND USABLE ON CODE (UOC)	(7) QTY
					GROUP 09 DOWN TUBE ASSEMBLY	
					FIG. 9 DOWN TUBE ASSEMBLY	
1	PAOZZ	4520-01-469-5745	92878	106351	BURNER TUBE ASSEMBLY	1
					END OF FIGURE	

THIS PAGE INTENTIONALLY LEFT BLANK

THIS PAGE INTENTIONALLY LEFT BLANK

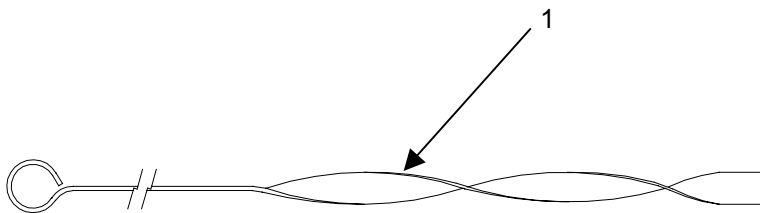

Figure 10. Group 10 Burner Reamer Tool

**GROUP 10 BURNER REAMER TOOL
PARTS LIST - continued**

0035 00

(1) ITEM NO.	(2) SMR CODE	(3) NSN	(4) CAGEC	(5) PART NUMBER	(6) DESCRIPTION AND USABLE ON CODE (UOC)	(7) QTY
					GROUP 10 BURNER REAMER TOOL	
					FIG. 10 BURNER REAMER TOOL	
1	PAOZZ	4520-01-469-5757	92878	106329	REAMER	1
					END OF FIGURE	

THIS PAGE INTENTIONALLY LEFT BLANK

THIS PAGE INTENTIONALLY LEFT BLANK

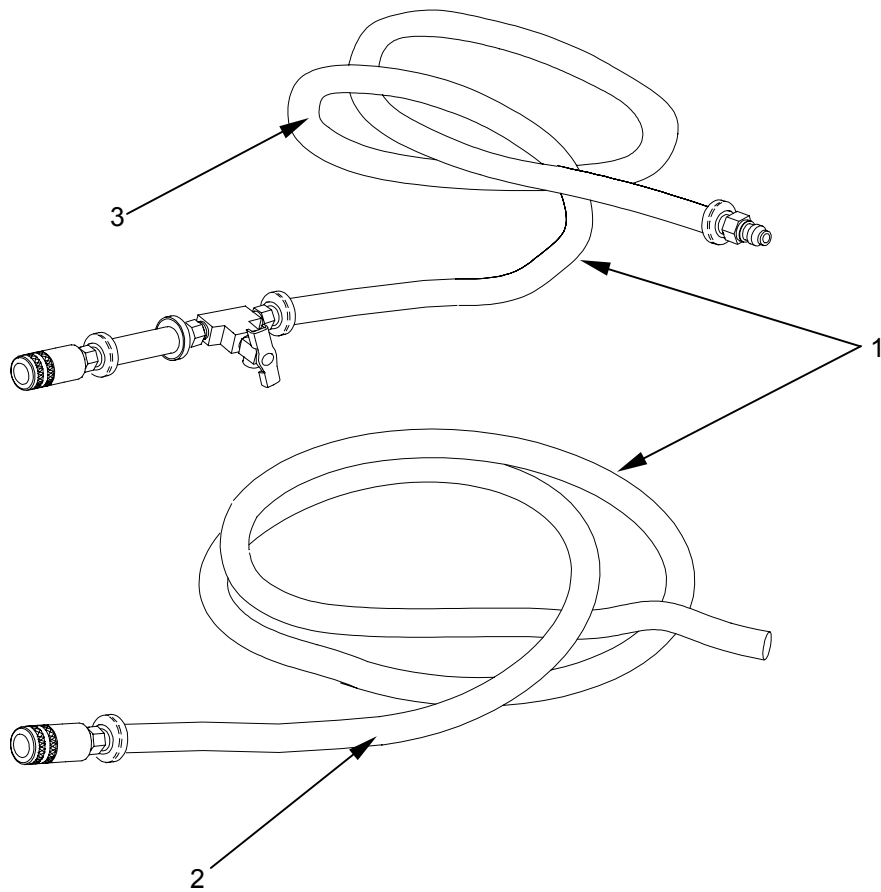

Figure 11. Group 11 Fuel Hose Kit

TM 10-4520-261-12&P

**GROUP 11 FUEL HOSE KIT
PARTS LIST - continued**

0036 00

(1) ITEM NO.	(2) SMR CODE	(3) NSN	(4) CAGEC	(5) PART NUMBER	(6) DESCRIPTION AND USABLE ON CODE (UOC)	(7) QTY
					GROUP 11 FUEL HOSE KIT	
					FIG. 11 FUEL HOSE KIT	
1	PAOZZ	4520-01-466-0420	92878	106367	FUEL HOSE KIT	1
2	PAOZZ	4520-01-466-5763	92878	106360	. HOSE ASSY, OVERFLOW	1
3	PAOZZ	4520-01-466-5771	92878	106361	. HOSE ASSY, FUEL SUPPLY	1
					END OF FIGURE	

THIS PAGE INTENTIONALLY LEFT BLANK

THIS PAGE INTENTIONALLY LEFT BLANK

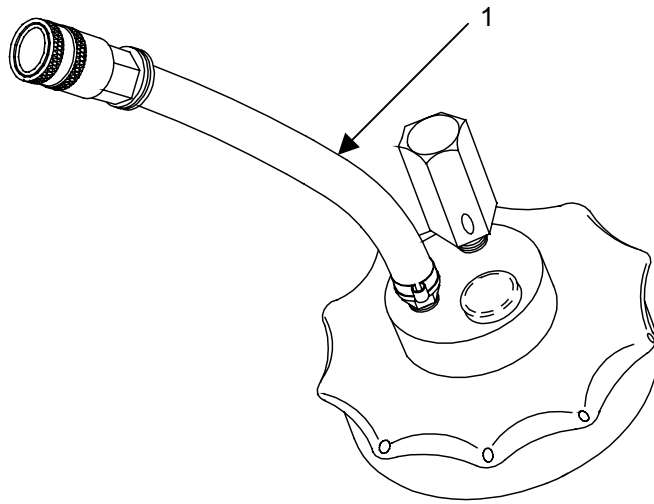

Figure 12. Group 12 Gravity Feed Adaptor

**GROUP 12 GRAVITY FEED ADAPTOR
PARTS LIST - continued**

0037 00

(1) ITEM NO.	(2) SMR CODE	(3) NSN	(4) CAGEC	(5) PART NUMBER	(6) DESCRIPTION AND USABLE ON CODE (UOC)	(7) QTY
					GROUP 12 GRAVITY FEED ADAPTOR	
					FIG. 12 GRAVITY FEED ADAPTOR	
1	PAOZZ	4520-01-469-5775	92878	171230	GRAVITY FEED ADAPTER	1
					END OF FIGURE	

THIS PAGE INTENTIONALLY LEFT BLANK

SPACE HEATER ARCTIC (SHA)

0038 00

BULK MATERIAL REPAIR PARTS LIST

(1) ITEM NO.	(2) SMR CODE	(3) NSN	(4) CAGEC	(5) PART NUMBER	(6) DESCRIPTION AND USABLE ON CODE (UOC)	(7) QTY
GROUP 14 BULK MATERIAL						
1	MOOZZ		92878	MIL-H-13444	HOSE, RUBBER, NITRILE, 3/8 IN. I.D.	AR
2	MOOZZ		92878	MIL-W-83420	WIRE ROPE 7 X 7 3/32	AR
END OF FIGURE						

THIS PAGE INTENTIONALLY LEFT BLANK

There are no special tools required for the Space Heater Arctic or its associated equipment.

THIS PAGE INTENTIONALLY LEFT BLANK

**SPACE HEATER ARCTIC (SHA)
NATIONAL STOCK NUMBER INDEX**

0040 00

STOCK NUMBER	FIG.	ITEM
4520-01-466-0409	5	1
4520-01-469-0420	11	1
4520-01-469-5534	1	1
4520-01-469-5545	2	1
4520-01-469-5551	3	1
4520-01-469-5561	4	1
4520-01-469-5567	5	2
4520-01-469-5571	5	4
4520-01-469-5576	5	3
4520-01-469-5578	6	1
4520-01-469-5585	7	1
4520-01-469-5743	8	1
4520-01-469-5745	9	1
4520-01-469-5757	10	1
4520-01-469-5763	11	2
4520-01-469-5771	11	3
4520-01-469-5775	12	1
4520-01-469-5779	3	2

THIS PAGE INTENTIONALLY LEFT BLANK

**SPACE HEATER ARCTIC (SHA)
PART NUMBER INDEX****0041 00**

PART NUMBER	FIG.	ITEM
MIL-W-83420	1	2
MIL-W-83420	5	5
MS51844-83	1	4
MS51844-83	5	6
3050	5	8
106261	8	1
106281	5	4
106329	10	1
106331	7	1
106332	3	2
106342	3	1
106351	9	1
106353	4	1
106354	5	2
106357	2	1
106358	6	1
106360	11	2
106361	11	3
106362	5	7
106363	5	3
106366	5	1
106367	11	1
171197	1	1
171218	1	3
171230	12	1

THIS PAGE INTENTIONALLY LEFT BLANK

INTRODUCTION

Scope

This section lists COEI and BII for the SHA to help you inventory items for safe and efficient operation of the equipment.

General

The COEI and BII information is divided into the following lists:

Components of End Item (COEI). This list is for information purposes only and is not authority to requisition replacements. These items are part of the SHA. As part of the end item, these must be with the end item whenever it is issued or transferred between property accounts. Items of COEI are removed and separately packaged for transportation or shipment only when necessary. Illustrations are furnished to help you find and identify the items.

Basic Issue Items (BII). These essential items are required to place the SHA in operation, operate it, and to do emergency repairs. Although shipped separately packaged, BII must be with the SHA during operation and when it is transferred between property accounts. Listing these items is your authority to request / requisition them for replacement based on authorization of the end item by the TOE/MTOE. Illustrations are furnished to help you find and identify the items.

Explanation of Columns in the COEI List and BII List

Column 1, Illu Number, gives you the number of the item illustrated.

Column 2, National Stock Number, identifies the stock number of the item to be used for requisitioning purposes.

Column 3, Description, CAGEC, and Part Number, identifies the Federal item name (in all capital letters) followed by a minimum description when needed. The last line below the description is the CAGEC (commercial and Government entity code) (in parenthesis) and the part number.

Column 4, Usable on code, gives you a code if the item you need is not the same for different models of equipment. There is no usable on code for the Space Heater Arctic.

Column 5, UM (unit of measure), indicates how the item is issued for the National Stock Number shown in column 2.

Column 6, Qty Rqr, indicates the quantity required.

SPACE HEATER ARCTIC (SHA)
COMPONENTS OF END ITEM (COEI) AND BASIC ISSUE ITEMS (BII) LIST

COMPONENTS OF END ITEM (COEI) LIST

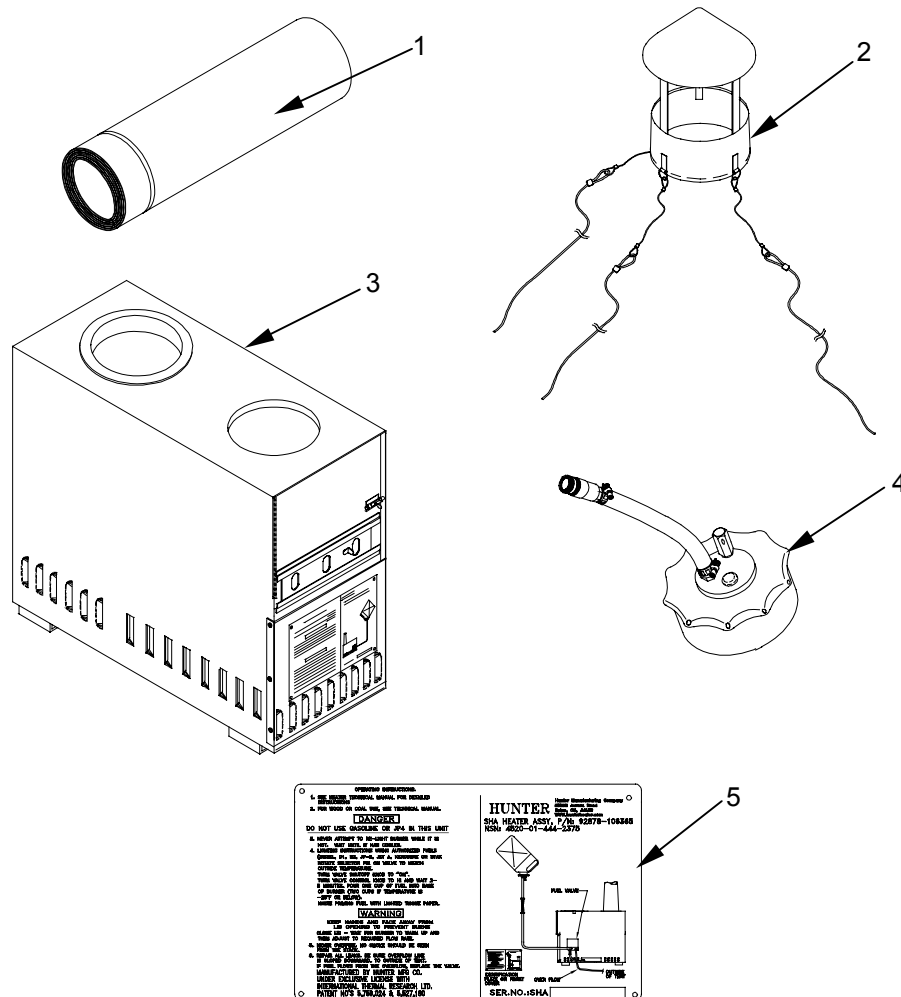

Table 1. Components of End Item List.

(1) ILLUS NUMBER	(2) NATIONAL STOCK NUMBER	(3) DESCRIPTION, LOCATION, PART NUMBER, AND (CAGEC)	(4) USABLE ON CODE	(5) U/M	(6) QTY RQR
1	4520-01-469-5545	STACK, EXHAUST NESTABLE 106357 (92878)		EA	1
2	4520-01-469-5534	STACK CAP ASSEMBLY 171197 (92878)		EA	1
3	4520-01-469-5551	HEATER WELDMENT ASSY 106342 (92878)		EA	1
4	4520-01-469-5775	GRAVITY FEED ADAPTOR 106368 (92878)		EA	1
5	4520-01-469-5779	IDENTIFICATION PLATE 106332 (92878)		EA	1

**SPACE HEATER ARCTIC (SHA)
COMPONENTS OF END ITEM (COEI) AND BASIC ISSUE ITEMS (BII) LIST**

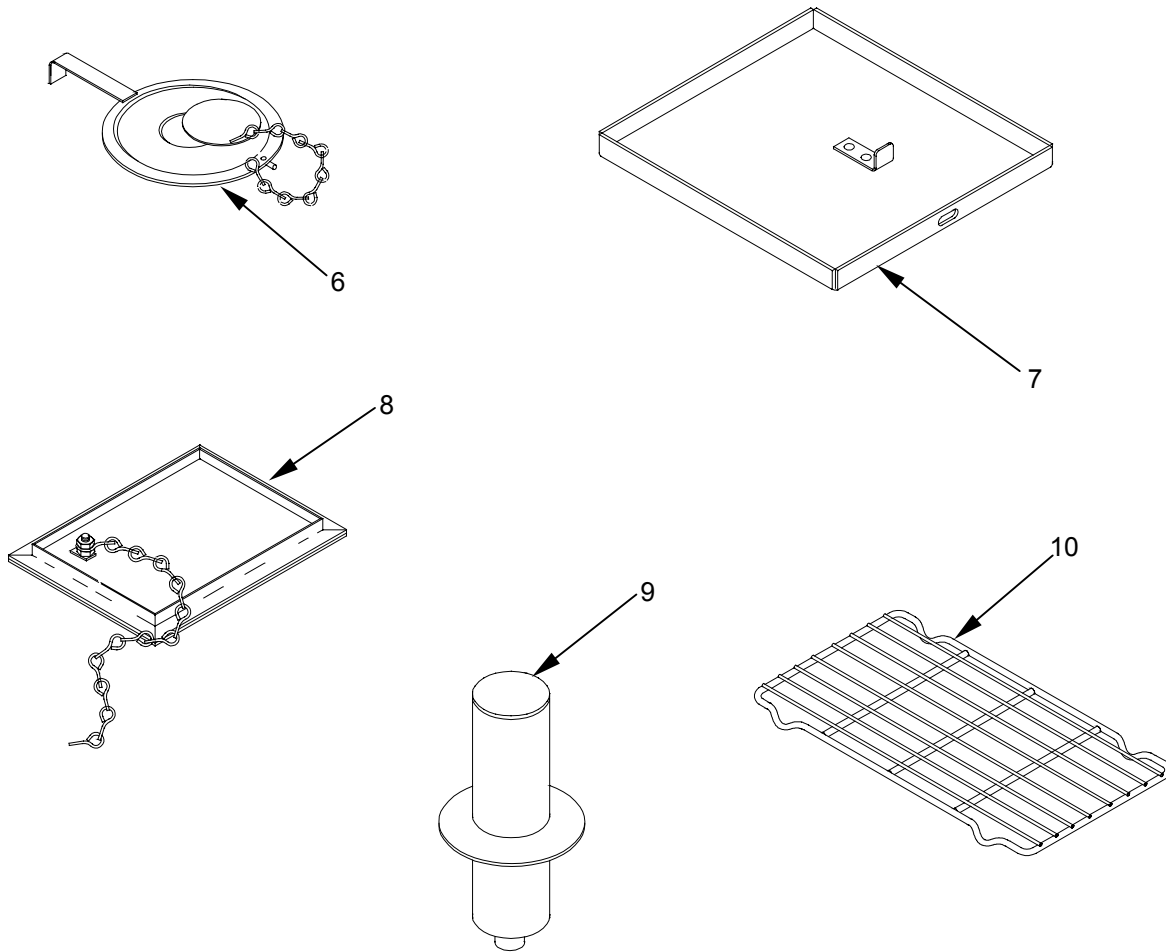

Table 1. Components of End Item List - Continued.

(1) ILLUS NUMBER	(2) NATIONAL STOCK NUMBER	(3) DESCRIPTION, LOCATION, PART NUMBER AND CAGEC	(4) USABLE ON CODE	(5) U/M	(6) QTY RQR
6	4520-01-469-5561	LID ASSEMBLY 106353 (92878)		EA	1
7	4520-01-469-5585	DOOR STORAGE WELDMENT 106331 (92878)		EA	1
8	4520-01-469-5743	BURNER COVER ASSEMBLY 106261 (92878)		EA	1
9	4520-01-469-5745	BURNER TUBE ASSEMBLY 106351 (92878)		EA	1
10	4520-01-469-5578	WIRE RACK ASSEMBLY 106358 (92878)		EA	1

**SPACE HEATER ARCTIC (SHA)
COMPONENTS OF END ITEM (COEI) AND BASIC ISSUE ITEMS (BII) LIST**

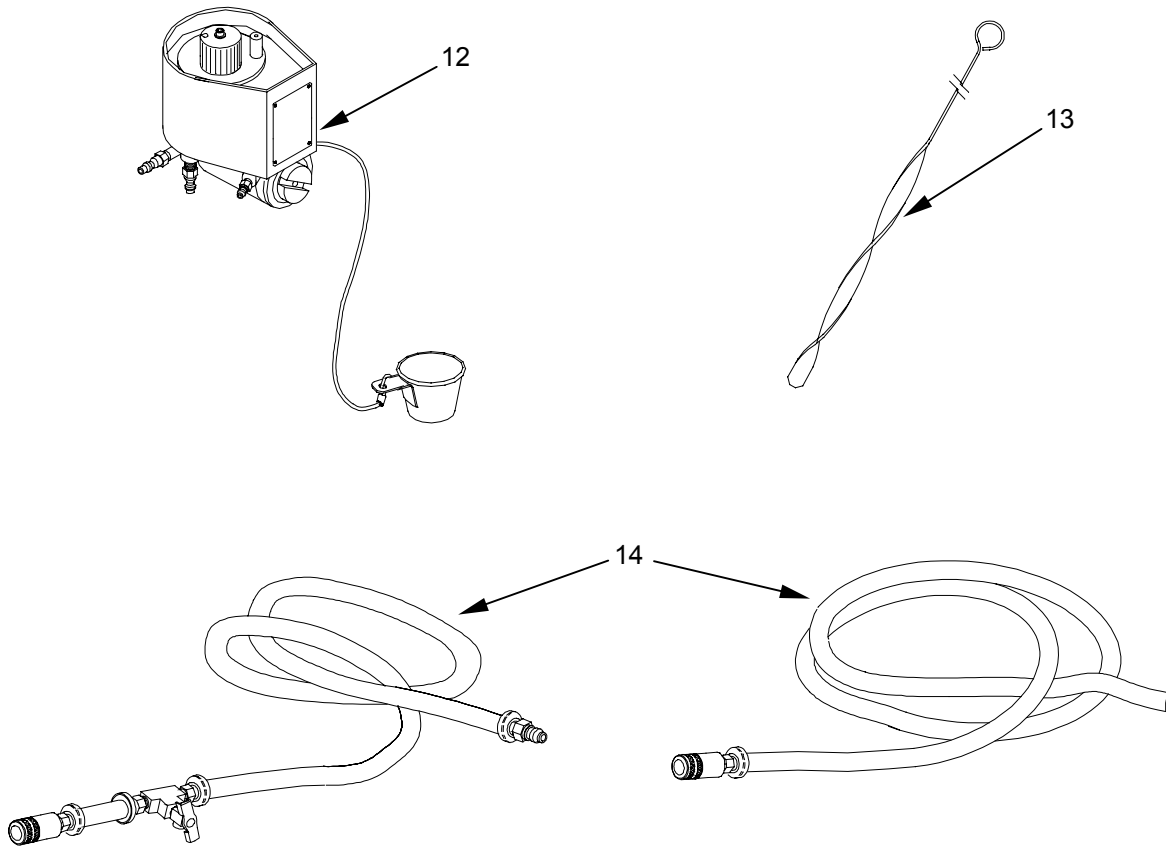

Table 1. Components of End Item List - Continued

(1) ILLUS NUMBER	(2) NATIONAL STOCK NUMBER	(3) DESCRIPTION, LOCATION, PART NUMBER AND CAGEC	(4) USABLE ON CODE	(5) U/M	(6) QTY RQR
12	4520-01-466-0409	FUEL FLOW CONTROL VALVE WITH CUP/CABLE/BRAKET ASSEMBLY 106366 (92878)		EA	1
13	4520-01-469-5757	REAMER 106329 (92878)		EA	1
14	4520-01-466-0420	FUEL HOSE KIT 106361 (92878)		EA	1

BASIC ISSUE ITEMS (BII) LIST

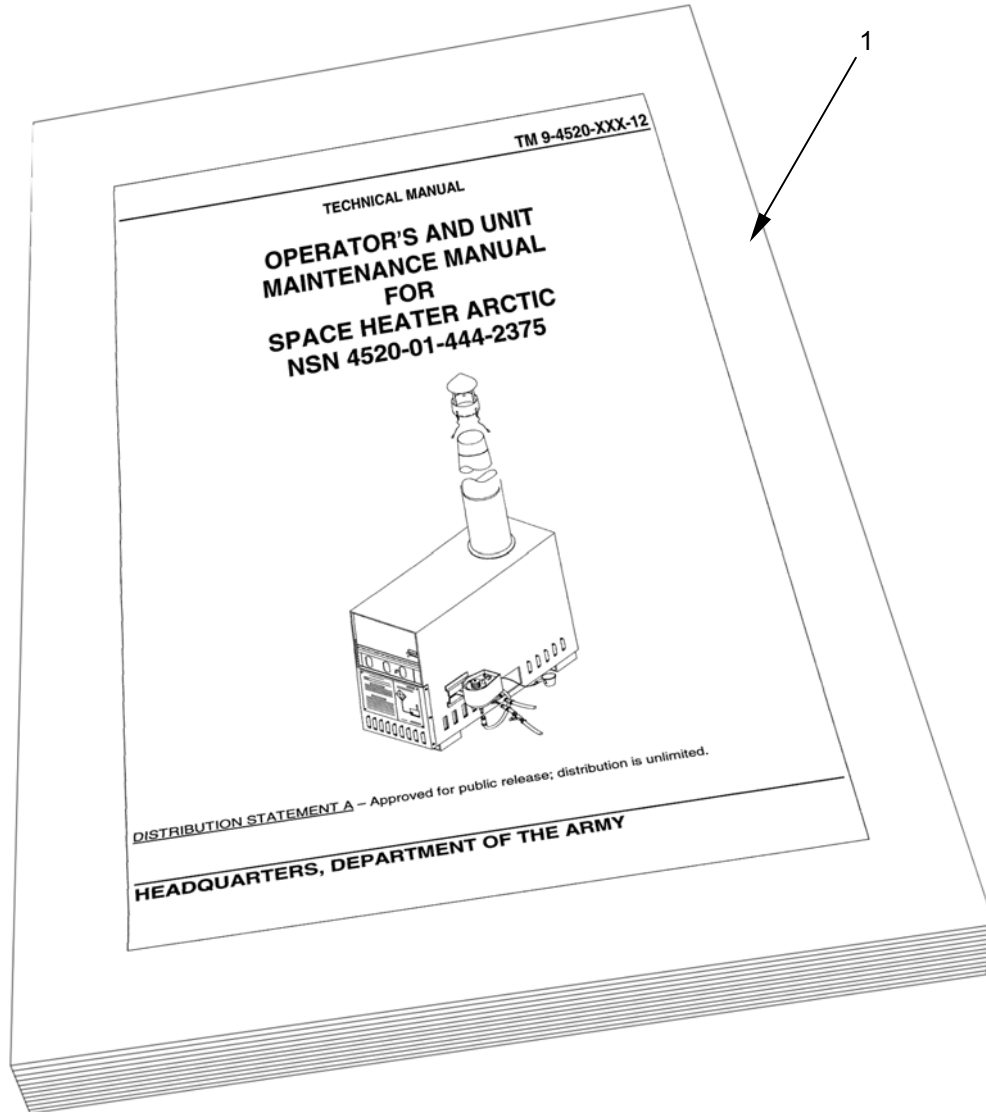

Table 2. Basic Issue Items List

(1) ILLUS NUMBER	(2) NATIONAL STOCK NUMBER	(3) DESCRIPTION, PART NUMBER AND CAGEC	(4) USABLE ON CODE	(5) U/M	(6) QTY RQR
1	N/A	TM 10-4520-261-12&P		EA	1

THIS PAGE INTENTIONALLY LEFT BLANK

**SPACE HEATER ARCTIC (SHA)
ADDITIONAL AUTHORIZATION LIST (AAL)**

INTRODUCTION

Scope

This section lists additional items you are authorized for the support of the SHA.

General

This list identifies items that do not have to accompany the SHA and that do not have to be turned in with it. These items are all authorized to you by CTA, MTOE, TDA, or JTA.

Explanation of Columns in the AAL:

Column (1) National Stock Number, identifies the stock number of the item to be used for requisitioning purposes.

Column (2) Description, CAGEC, and Part Number, identifies the Federal Item Name (in all capital letters) followed by a minimum description when needed. The last line below the description is the CAGE (Commercial and Government Entity Code) (in parenthesis) and the part number.

Column (3), Usable On Code, when applicable, gives you a code if the item you need is not the same for different models of equipment.

Column (4), UM (unit of measure) indicates how the item is issued for the National Stock Number shown in column (1).

Column (5), Qty Recm, indicates the quantity recommended.

ADDITIONAL AUTHORIZED LIST ITEMS

Table 1. Additional Authorization List.

(1) NATIONAL STOCK NUMBER	(2) DESCRIPTION, (CAGEC) AND PART NUMBER	(3) USABLE ON CODE	(4) U/M	(5) QTY RECM
4140-01-457-2790	THERMOELECTRIC FAN (1EJ96) TEF-III		EA	1
7240-01-337-5268	CAN (DT), GASOLINE, MILITARY (81349) MIL-C-53109		EA	1
7240-01-337-5269	CAN (CG), GASOLINE, MILITARY (81349) MIL-C-53109		EA	1
4520-01-465-4430	FUEL CAN STAND, COLLAPISBLE		EA	1

THIS PAGE INTENTIONALLY LEFT BLANK

**SPACE HEATER ARCTIC (SHA)
EXPENDABLE AND DURABLES ITEMS LIST**

INTRODUCTION

Scope

This section lists expendable and durable items that you will need to operate and maintain the SHA. This list is for information only and is not authority to requisition the listed items. These items are authorized to you by CTA 50-970, Expendable/Durable Items (Except Medical, Class V Repair Parts, and Heraldic Items), or CTA 8-100, Army Medical Department Expendable/Durable Items.

Explanations of Columns in the Expendable / Durable Items List

Column (1) Item Number. This number is assigned to the entry in the list and is referenced in the narrative instructions to identify the item (e.g., Use lubricating oil (WP0046, Table 1, Item 1).

Column (2) Level. This column includes the lowest level of maintenance that requires the listed item.

- C** Operator or Crew
- O** Unit Maintenance
- F** Direct Support Maintenance
- H** General Support Maintenance
- D** Depot Maintenance

Column (3) National Stock Number. This is the NSN assigned to the item which you can use to requisition it.

Column (4) Item Name, Description, CAGEC, and Part Number. This column provides the other information you need to identify the item.

Column (5), U/M (unit of measure) indicates how the item is issued for the National Stock Number shown in column (1).

EXPENDABLE AND DURABLE ITEMS LIST

Table 1. Expendable and Durable Items List

(1) ITEM NUMBER	(2) LEVEL	(3) NATIONAL STOCK NUMBER	(4) ITEM NAME, DESCRIPTION, (CAGEC), PART NUMBER	(5) U/M
1	O	7920-00-205-3570	WIPING RAGS	LB
2	O	6850-00-644-5685	SOLVENT, DRYCLEANING (81349) P-D-860	GL
3	O	4720-00-273-9514	HOSE, RUBBER, NITRILE, 3/8 IN. I.D. (81349) MIL-H-13444	FT
4	O		GASKET, RUBBER (81349) MIL-G-432	EA
5	O		CLAMP, HOSE (SIZE 06) (81349) SAE-J-I508,TYPE M	EA
6	O		STRAINER (81349)	EA
7	O		GASKET, CORK (81349) 171233	EA

**SPACE HEATER ARCTIC (SHA)
EXPENDABLE AND DURABLES ITEMS LIST**

0044 00

Table 1. Expendable and Durable Items List – Continued

8	O	4010-00-222-4474	ROPE, WIRE (81349) MIL-W-83420 TYPE I	FT
9	O		SLEEVE, SWAGING (81349) MS51844-83	BX
10	O	4520-00-233-6565	ROPE, NYLON (92878) 171218	FT

INTRODUCTION

Scope

This work package includes a list of all mandatory replacement parts referenced in the task initial setups and procedures. These are items that must be replaced during maintenance whether they have failed or not. This includes items based on usage intervals such as miles, time, rounds fired, etc.

MANDATORY REPLACEMENT PARTS LIST

There are no mandatory replacement parts for the Space Heater Arctic.

THIS PAGE INTENTIONALLY LEFT BLANK

SPACE HEATER ARCTIC (SHA)
ALPHABETICAL INDEX

ALPHABETICAL INDEX

A

Abbreviations and Acronyms 0001 00-3
 Additional Authorization List (AAL) 0045 00-1
 Army Maintenance System MAC 0025 00-1
 Assembly And Preparation For Use..... 0005 00-1

B

Basic Issue Items (BI) List..... 0044 00-5
 Bulk Material Repair Parts List..... 0040 00-1

C

Cleaning 0014 00-1
 Common Tools And Equipment 0002 00-6
 Components Of End Item (COEI) List..... 0044 00-1
 Controls And Indicators 0004 00-1
 Corrosion Prevention And Control (CPC) 0001 00-2

D

Decals And Instruction Plates 0004 00-3
 Description and Use of Operator=s Controls and Indicators 0004 00-1
 Destruction Of Army Materiel To Prevent Enemy Use 0001 00-2
 Description Of System Components 0002 00-1
 Direct Support Maintenance Procedures 0023 00-1

E

Environmental Limits on Equipment 0002 00-5
 Equipment Characteristics, Capabilities And Features..... 0001 00-3
 Equipment Data 0002 00-5
 Equipment Improvements and Recommendations, Reporting (EIR)..... 0001 00-2
 Expendable and Durable Items List 0046 00-1
 Explanation of Columns in the MAC 0025 00-2
 Explanation of Columns in the Tools and Test Equipment Requirements 0025 00-3
 Explanation of Columns in Remarks 0025 00-3

F

Field Manuals 0024 00-1
 Forms 0024 00-1

**SPACE HEATER ARCTIC (SHA)
ALPHABETICAL INDEX**

G

General Information..... 0001 00-1

H

How to Locate Repair Parts 0026 00-7
How to Use this Manual v

I

Introduction To Components Of End Item (COEI) and Basic Issue Items (BII) List 0044 00-1
Introduction To Maintenance Allocation Chart 0025 00-1

L

List Of Abbreviations/Acronyms 0001 00-3
Location And Description Of Major Components 0002 00-1
Lubrication Service Intervals 0010 00-2

M

Maintenance Allocation Chart For SHA System 0025 00-4
Maintenance Forms Records And Reports 0024 00-1
Maintenance Functions 0025 00-1
Maintenance, Direct Support..... 0023 00-1
Maintenance Procedures, Unit.....0014 00-1 thru 0022 00-1
Malfunction Symptom Index..... 0008 00-1
Mandatory Replacement Parts 0047 00-1

N

National Stock Number Index 0041 00-1
Nomenclature Cross-Reference List..... 0001 00-2

O

Operations under Usual Conditions 0005 00-1
Operation In Unusual Environment/Weather Conditions 0006 00-1
Operating Procedures 0005 00-11
Operator Services 0010 00-1

P

Pamphlets 0024 00-1
Part Number Index 0043 00-1

**SPACE HEATER ARCTIC (SHA)
ALPHABETICAL INDEX**

Preparation For Movement 0005 00-21
 Preparing SHA and Associated Equipment For Storage 0005 00-21
 Preventive Maintenance Checks And Services (PMCS) 0010 00-1

Q

Quality Deficiency Report 0024 00-1

R

References 0024 00-1
 Remarks For SHA 0025 00-5
 Repair Parts and Special Tools List 0026 00-1
 Reporting Equipment Improvement Recommendations (EIRs) 0001 00-1
 Reporting Errors and Recommending Improvements 0024 00-1

S

Safety, Care And Handling, Warnings, Cautions And Notes 0001 00-3
 Service upon Receipt 0012 00-1
 Siting Requirements 0005 00-1
 Special Tools List 0042 00-1

T

Table of Contents i
 Technical Manuals 0024 00-1
 Theory Of Operation 0003 00-1
 Tools And Test Equipment Requirements For SHA 0025 00-5
 Troubleshooting Procedures 0009 00-1

U

Unit Maintenance Procedures 0014 00-1 thru 0022 00-1
 Unpacking 0005 00-1
 Usable On Code 0026 00-7

V

W

Warnings a

THIS PAGE INTENTIONALLY LEFT BLANK

By Order of the Secretary of the Army:

Official:



JOEL B. HUDSON

*Administrative Assistant to the
Secretary of the Army*

0133801

ERIC K. SHINSEKI
*General, United States Army
Chief of Staff*

DISTRIBUTION:

To be distributed in accordance with initial distribution IDN 256708 requirements for
TM 10-4520-261-12&P.

THIS PAGE INTENTIONALLY LEFT BLANK

These are the instructions for sending an electronic 2028

The following format must be used if submitting an electronic 2028. The subject line must be exactly the same and all fields must be included; however only the following fields are mandatory: 1, 3, 4, 5, 6, 7, 8, 9, 10, 13, 15, 16, 17, and 27.

From: "Whomever" <whomever@avma27.army.mil>

To: amssb-rim-e@natick.army.mil

Subject: DA Form 2028

1. **From:** Joe Smith
2. **Unit:** home
3. **Address:** 4300 Park
4. **City:** Hometown
5. **St:** MO
6. **Zip:** 77777
7. **Date Sent:** 19-OCT-93
8. **Pub no:** 55-2840-229-23
9. **Pub Title:** TM
10. **Publication Date:** 04-JUL-85
11. **Change Number:** 7
12. **Submitter Rank:** MSG
13. **Submitter FName:** Joe
14. **Submitter MName:** T
15. **Submitter LName:** Smith
16. **Submitter Phone:** 123-123-1234
17. **Problem:** 1
18. **Page:** 2
19. **Paragraph:** 3
20. **Line:** 4
21. **NSN:** 5
22. **Reference:** 6
23. **Figure:** 7
24. **Table:** 8
25. **Item:** 9
26. **Total:** 123
27. **Text:**

This is the text for the problem below line 27.

THIS PAGE INTENTIONALLY LEFT BLANK



THEN . . . JOT DOWN THE DOPE ABOUT IT ON THIS FORM, CAREFULLY TEAR IT OUT, FOLD IT AND DROP IT IN THE MAIL!

SOMETHING WRONG WITH THIS PUBLICATION?

FROM: (PRINT YOUR UNIT'S COMPLETE ADDRESS)

*PFC John DOE
CO A 3rd Engineer Bn
Ft. Leonardwood, MO 63108*

DATE SENT

22 August 1992

PUBLICATION NUMBER

TM 1-1520-250-10

PUBLICATION DATE

15 June 1992

PUBLICATION TITLE

Operator's manual MH60K Helicopter

BE EXACT PIN-POINT WHERE IT IS

IN THIS SPACE, TELL WHAT IS WRONG AND WHAT SHOULD BE DONE ABOUT IT:

PAGE NO	PARA-GRAPH	FIGURE NO	TABLE NO
6	2-1 a		
B1		4-3	

In line 6 of paragraph 2-1a the manual states the engine has 6 cylinders. The engine on my set only has 4 cylinders. Change the manual to show 4 cylinders.

Callout 16 on figure 4-3 is pointed at a bolt. In key to figure 4-3, item 16 is called a shim. Please correct one or the other

PRINTED NAME, GRADE OR TITLE, AND TELEPHONE NUMBER

JOHN DOE, PFC (268) 317-7111

SIGN HERE

John Doe
JOHN DOE

FILL IN YOUR
UNITS ADDRESS



FOLD BACK

DEPARTMENT OF THE ARMY

OFFICIAL BUSINESS

COMMANDER
U.S. SOLDIER AND BIOLOGICAL CHEMICAL COMMAND
ATTN: AMSSB-RIM-E(N)
KANSAS STREET
NATICK, MA 01760-5052

TEAR ALONG PERFORATED LINE

FILL IN YOUR
UNITS ADDRESS



FOLD BACK

DEPARTMENT OF THE ARMY

OFFICIAL BUSINESS

COMMANDER
U.S. SOLDIER AND BIOLOGICAL CHEMICAL COMMAND
ATTN: AMSSB-RIM-E(N)
KANSAS STREET
NATICK, MA 01760-5052

TEAR ALONG PERFORATED LINE

FILL IN YOUR
UNITS ADDRESS



FOLD BACK

DEPARTMENT OF THE ARMY

OFFICIAL BUSINESS

COMMANDER
U.S. SOLDIER AND BIOLOGICAL CHEMICAL COMMAND
ATTN: AMSSB-RIM-E(N)
KANSAS STREET
NATICK, MA 01760-5052

TEAR ALONG PERFORATED LINE

FILL IN YOUR
UNITS ADDRESS



FOLD BACK

DEPARTMENT OF THE ARMY

OFFICIAL BUSINESS

COMMANDER
U.S. SOLDIER AND BIOLOGICAL CHEMICAL COMMAND
ATTN: AMSSB-RIM-E(N)
KANSAS STREET
NATICK, MA 01760-5052

TEAR ALONG PERFORATED LINE

The Metric System and Equivalents

Linear Measure

1 centimeter = 10 millimeters = .39 inch
 1 decimeter = 10 centimeters = 3.94 inches
 1 meter = 10 decimeters = 39.37 inches
 1 dekameter = 10 meters = 32.8 feet
 1 hectometer = 10 dekameters = 328.08 feet
 1 kilometer = 10 hectometers = 3,280.8 feet

Weights

1 centigram = 10 milligrams = .15 grain
 1 decigram = 10 centigrams = 1.54 grains
 1 gram = 10 decigrams = .035 ounce
 1 dekagram = 10 grams = .35 ounce
 1 hectogram = 10 dekagrams = 3.52 ounces
 1 kilogram = 10 hectograms = 2.2 pounds
 1 quintal = 100 kilograms = 220.46 pounds
 1 metric ton = 10 quintals = 1.1 short tons

Liquid Measure

1 centiliter = 10 milliliters = .34 fl. ounce
 1 deciliter = 10 centiliters = 3.38 fl. ounces
 1 liter = 10 deciliters = 33.81 fl. ounces
 1 dekaliter = 10 liters = 2.64 gallons
 1 hectoliter = 10 dekaliters = 26.42 gallons
 1 kiloliter = 10 hectoliters = 264.18 gallons

Square Measure

1 sq. centimeter = 100 sq. millimeters = .155 sq. inch
 1 sq. decimeter = 100 sq. centimeters = 15.5 sq. inches
 1 sq. meter (centare) = 100 sq. decimeters = 10.76 sq. feet
 1 sq. dekameter (are) = 100 sq. meters = 1,076.4 sq. feet
 1 sq. hectometer (hectare) = 100 sq. dekameters = 2.47 acres
 1 sq. kilometer = 100 sq. hectometers = .386 sq. mile

Cubic Measure

1 cu. centimeter = 1000 cu. millimeters = .06 cu. inch
 1 cu. decimeter = 1000 cu. centimeters = 61.02 cu. inches
 1 cu. meter = 1000 cu. decimeters = 35.31 feet

Approximate Conversion Factors

<i>To change</i>	<i>To</i>	<i>Multiply by</i>	<i>To change</i>	<i>To</i>	<i>Multiply by</i>
inches	centimeters	2.540	ounce-inches	newton-meters	.007062
feet	meters	.305	centimeters	inches	.394
yards	meters	.914	meters	feet	3.280
miles	kilometers	1.609	meters	yards	1.094
square inches	square centimeters	6.451	kilometers	miles	.621
square feet	square meters	.093	square centimeters	square inches	.155
square yards	square meters	.836	square meters	square feet	10.764
square miles	square kilometers	2.590	square meters	square yards	1.196
acres	square hectometers	.405	square kilometers	square miles	.386
cubic feet	cubic meters	.028	square hectometers	acres	2.471
cubic yards	cubic meters	.765	cubic meters	cubic feet	35.315
fluid ounces	milliliters	29.573	cubic meters	cubic yards	1.308
pints	liters	.473	milliliters	fluid ounces	.034
quarts	liters	.946	liters	pints	2.113
gallons	liters	3.785	liters	quarts	1.057
ounces	grams	28.349	liters	gallons	.264
pounds	kilograms	.454	grams	ounces	.035
short tons	metric tons	.907	kilograms	pounds	2.205
pound-feet	newton-meters	1.356	metric tons	short tons	1.102
pound-inches	newton-meters	.11296			

Temperature (Exact)

_F	Fahrenheit temperature	5/9 (after subtracting 32)	Celsius temperature	_C
----	---------------------------	-------------------------------	------------------------	----

PIN: 079445-000